

NIVE

Instruction Book

AUSTRALIA



Lacunza congratulates you on your choice.
Certified under ISO 9001, Lacunza guarantees the quality of its appliances and undertakes to meet the needs of its customers.

Confident of the know-how afforded by more than 50 years' experience, Lacunza uses advanced technologies in the design and manufacture of its entire range of appliances. This document will help you install and use your appliance in optimum conditions for your comfort and safety.

CONTENTS

1. PRESENTATION OF THE APPLIANCE	3
1.1. General characteristics.....	3
2. INSTRUCTIONS FOR THE INSTALLER.....	11
2.1. Warning to installers	11
2.2. Room for installation.....	11
2.2.1. Location of the appliance in the room.....	11
2.3. Installation of the appliance.....	11
2.3.1. Safety distances for freestanding	11
2.3.2. Elevation clearance	12
2.3.3. Safety distances fo in built and zero clearance box	13
2.3.4. Checks before lighting for the first time.....	16
2.3.5. Height adjustment and levelling the appliance	16
2.3.6. Casing.....	16
2.3.7. Preparing the outside air conection.....	17
2.3.8. Connection to the flue	18
2.3.9. Piping air to other rooms (only for Nive version with fan installed, not for Nive F).....	18
2.3.10. Exterior Frame. Removal and assembly (only for Nive version, not for Nive F)	20
2.3.11. Turbine-potentiometer connection (Only for models with fan installed).....	20
2.1. Masonry section	21
2.2. Chimney flue	21
2.2.1. Type of flue.....	22
2.2.2. Chimney crown.....	23
3. INSTRUCTIONS OF USE	24
3.1. Fuel.....	24
3.2. Description of the parts of the appliance	25
3.2.1. Operating components	25
3.3. Lighting.....	26
3.4. Loading fuel	26
3.5. Operation	26
3.6. Removing ash	27
3.7. Deflectors	27



3.8. Electrical system.....	28
4. MAINTENANCE AND IMPORTANT ADVICE.....	30
4.1. Maintenance of the appliance.....	30
4.1.1. Firebox	30
4.1.2. Inside the appliance	30
4.1.3. Flue socket	30
4.1.4. Firebox glass.....	30
4.1.5. Painted sheet-steel-cast-iron parts.....	30
4.1.6. Electrical system	30
4.1.7. Air intake registers.....	30
4.2. Maintenance of the chimney flue.....	31
4.3. Important advice.....	31
5. TROUBLESHOOTING.....	32
6. BASIC BREAKDOWNS	33
7. PRODUCT RECYCLING.....	36
8. CERTIFICATE OF COMPLIANCE	37

1. PRESENTATION OF THE APPLIANCE

For optimum operation of the appliance, we advise you to read this manual carefully before switching on the appliance for the first time. In case of problems or concerns, we urge you to contact your dealer, who will cooperate with you.

In order to improve the product, the manufacturer reserves the right to make changes without notice by updating this document.

This appliance is designed to burn wood in absolutely safe conditions.

WARNING: Faulty installation may have serious consequences.

Installation and all necessary regular maintenance operations must be performed by an authorized installer in full accordance with the specifications set out in the legislation applicable in each country and this instruction book.

1.1. General characteristics

	Unit	NIVE 800 NIVE 800 F	NIVE 1000 NIVE 1000 F	
MAXIMUM AVERAGE HEAT OUTPUT BURNING HARDWOOD	kW	5.6	9.2	
OVERALL AVERAGE EFFICIENCY BURNING HARDWOOD	%	65	67	
PARTICULATE EMISSIONS FACTOR	g/kg	0.9	1.0	
HIGH BURN	Average power (high primary air settings)	kW	5.6	9.2
	Average Peak Power	kW	9.5	13.6
	Efficiency (high primary air settings)	%	62	55
	Average dry fuel consumption rate (high primary air settings)	Kg/hr	1.6	3.1
	Particulate emission factor oven dry wood (high primary air settings)	g/kg	0.8	0.5
MEDIUM BURN	Average power (medium primary air settings)	kW	4.1	7
	Efficiency (medium primary air settings)	%	62	75
	Average dry fuel consumption rate (medium primary air settings)	Kg/hr	1.2	1.7
	Particulate emission factor oven dry wood (medium primary air settings)	g/kg	0.7	1
LOW BURN	Average power (low primary air settings)	kW	3.9	4.5
	Efficiency (low primary air settings)	%	70	72
	Average dry fuel consumption rate (low primary air settings)	Kg/hr	1	1.1
	Particulate emission factor oven dry wood (low primary air settings)	g/kg	1.1	1.4
Dimensions of the firebox				
Width	mm	654	854	
Depth	mm	290	290	
Useful height	mm	300	300	
Length of the logs	cm	60	80	
Weight	kg	91	111	
Flue socket diameter	mm	150	150	

WARNINGS

KEEP THESE INSTRUCTIONS FOR FUTURE REFERENCE!

WARNING: THE APPLIANCE AND FLUE SYSTEM SHOULD BE INSTALLED IN ACCORDANCE WITH AS/NZS 2918 AND THE APPROPRIATE REQUIREMENTS OF THE RELEVANT BUILDING CODE OR CODES.

WARNING: APPLIANCES INSTALLED IN ACCORDANCE WITH AS/NZS 2918 SHOULD CONFORM TO THE REQUIREMENTS OF AS/NZS 4013 AND AS/NZS 4012 WHERE REQUIRED BY THE REGULATORY AUTHORITY. THE APPLIANCE SHOULD BE IDENTIFIABLE BY A CONFORMANCE PLATE MARKED 'TESTED TO AS/NZS 4013 AND AS/NZS 4012' AS SPECIFIED IN AS/NZS 4012 ANY MODIFICATION OF THE APPLIANCE THAT HAS NOT BEEN APPROVED IN WRITING BY THE TESTING AUTHORITY IS CONSIDERED TO BE IN BREACH OF THE APPROVAL GRANTED FOR CONFORMANCE TO AS/NZS 4013.

WARNING: ANY MODIFICATION OF THE APPLIANCE THAT HAS NOT BEEN APPROVED IN WRITING BY THE TESTING AUTHORITY IS CONSIDERED NOT CONFORMING TO AS/NZS 4013.

WARNING: DO NOT USE FLAMMABLE LIQUIDS OR AEROSOLS TO START OR REKINDLE THE FIRE.

WARNING: DO NOT USE FLAMMABLE LIQUIDS OR AEROSOLS IN THE VICINITY OF THIS APPLIANCE WHEN IT IS OPERATING.

WARNING: DO NOT STORE FUEL WITHIN HEATER INSTALLATION CLEARANCES.

WARNING: WHEN OPERATING THIS APPLIANCE AS AN OPEN FIRE, USE A FIRE SCREEN.

WARNING: OPEN THE AIR CONTROL (AND DAMPER WHEN FITTED) BEFORE OPENING THE FIRING DOOR

WARNING: DO NOT BURN WOOD THAT IS PAINTED, COATED WITH PLASTIC, OR HAS BEEN TREATED WITH ANY CHEMICAL.

CAUTIONS

CAUTION: MIXING APPLIANCE OR FLUE SYSTEM COMPONENTS FROM DIFFERENT SOURCES OR MODIFYING THE DIMENSIONAL SPECIFICATION OF COMPONENTS MAY RESULT IN HAZARDOUS CONDITIONS. WHERE SUCH ACTION IS CONSIDERED, THE MANUFACTURER SHOULD BE CONSULTED IN THE FIRST INSTANCE.

CAUTION: CRACKED AND BROKEN COMPONENTS, FOR EXAMPLE, GLASS PANELS OR CERAMIC TILES, MAY RENDER THE INSTALLATION UNSAFE

CAUTION: DO NOT OPERATE THIS APPLIANCE IF GLASS IS CRACKED OR BROKEN.

CAUTION: THIS APPLIANCE SHOULD BE MAINTAINED AND OPERATED AT ALL TIMES IN ACCORDANCE WITH THESE INSTRUCTIONS.

Warning: this appliance is designed and prepared to work with the types of fuel, degree of humidity of the fuel, fuel loads, fuel load frequencies, flue draught and system of installation indicated in this Instruction Book. Failure to respect these conditions may lead to problems with the appliance (deterioration, shorter useful life, etc.) which are not covered by the Lacunza warranty.

To obtain these data, tests have been done on the standards AS/NZS 4012 (2014), AS/NZS 4013 (2014) and AS/NZS 2918 (2018), with eucalyptus wood.

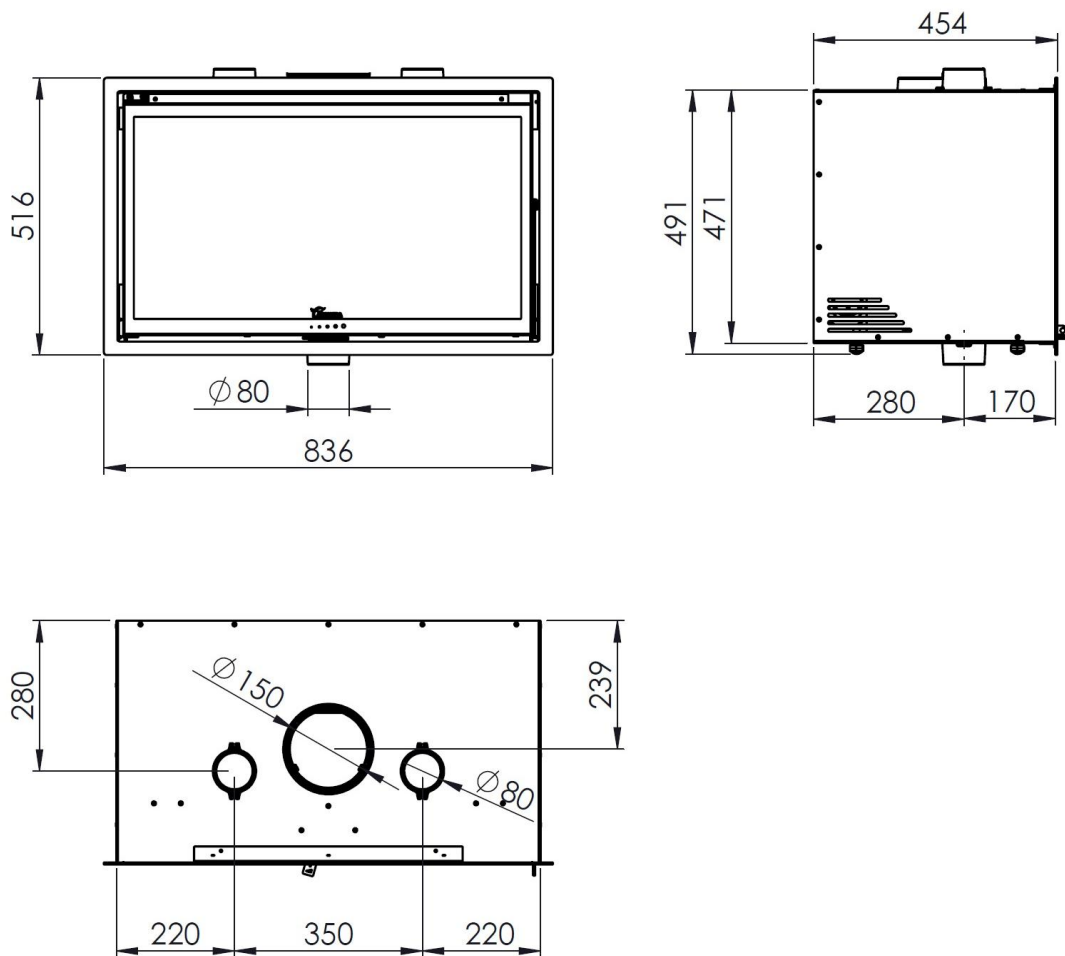
IN BUILT


Figure No.1 - Dimensions of the NIVE 800 In Built appliance in mm

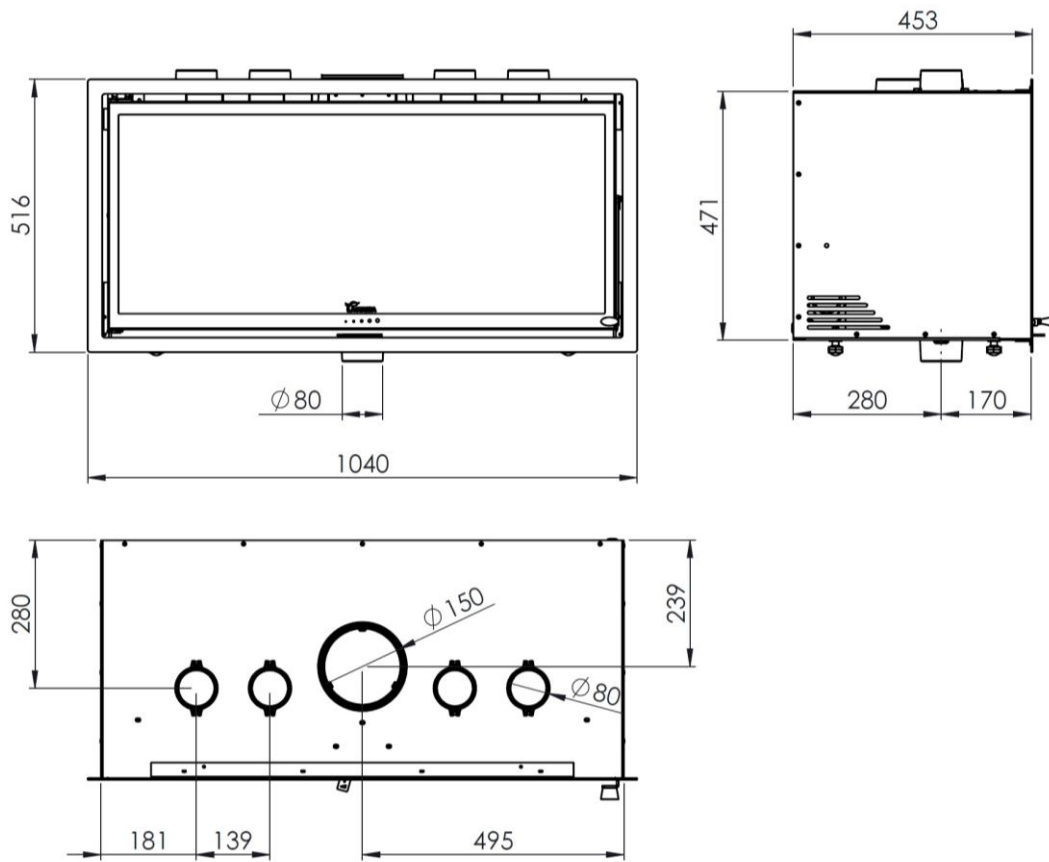


Figure No.2 - Dimensions of the NIVE 1000 In Built appliance in mm

FREESTANDING

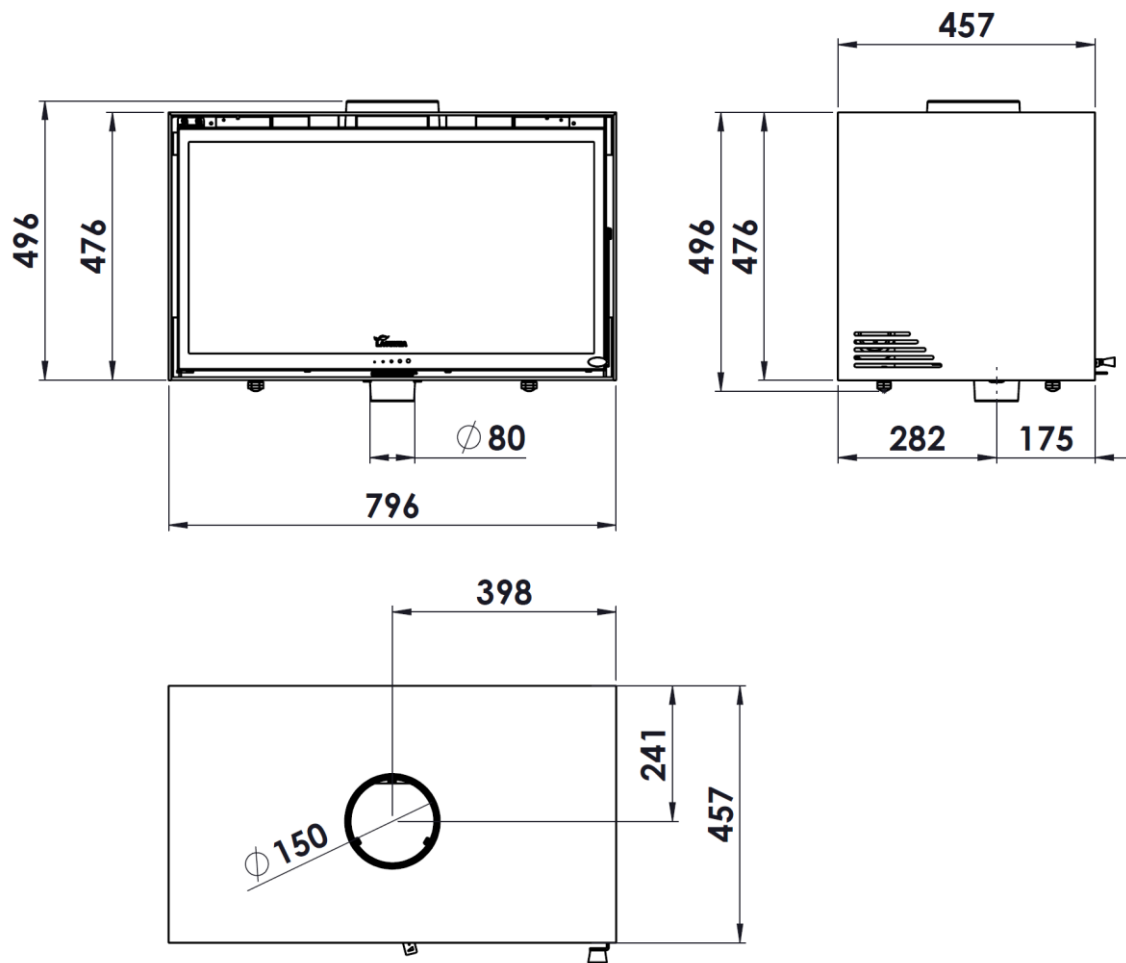


Figure No.3 - Dimensions of the NIVE 800 Free-standing appliance in mm

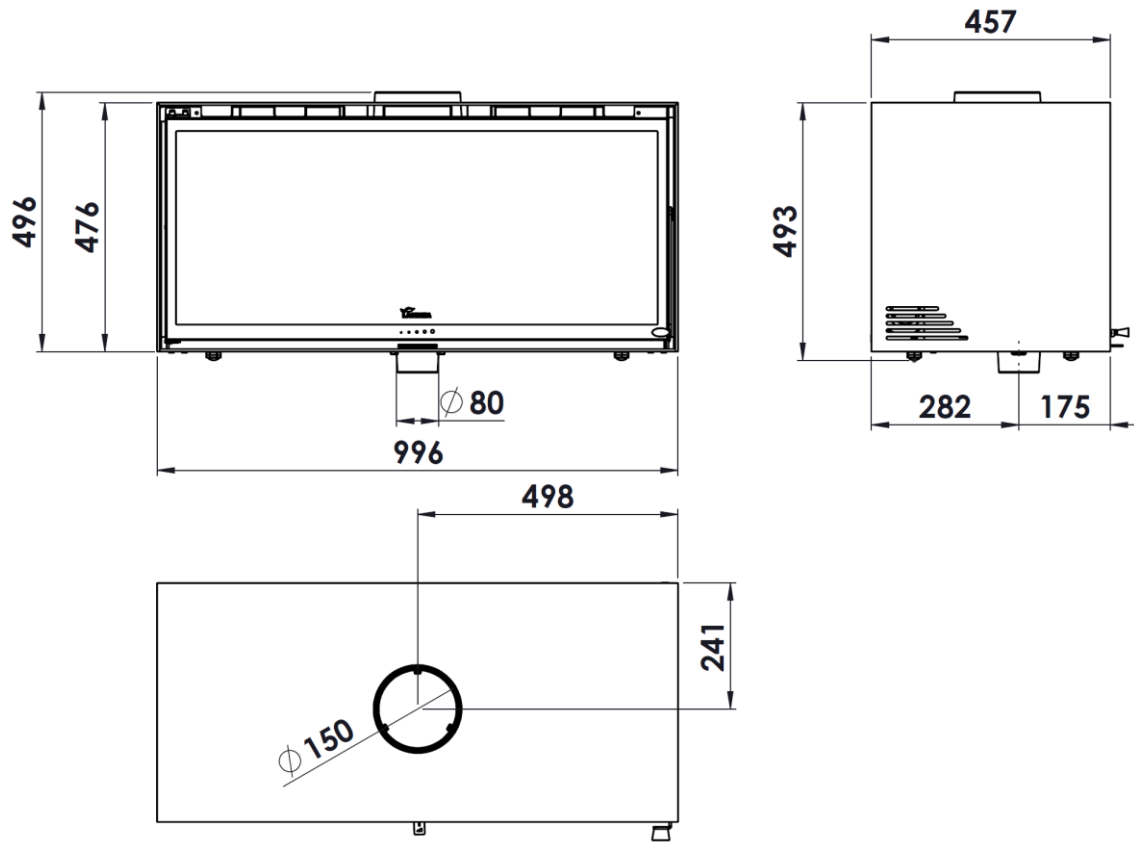


Figure No.4 - Dimensions of the NIVE 1000 Free-standing appliance in mm



FREESTANDING WITH WOODBOX

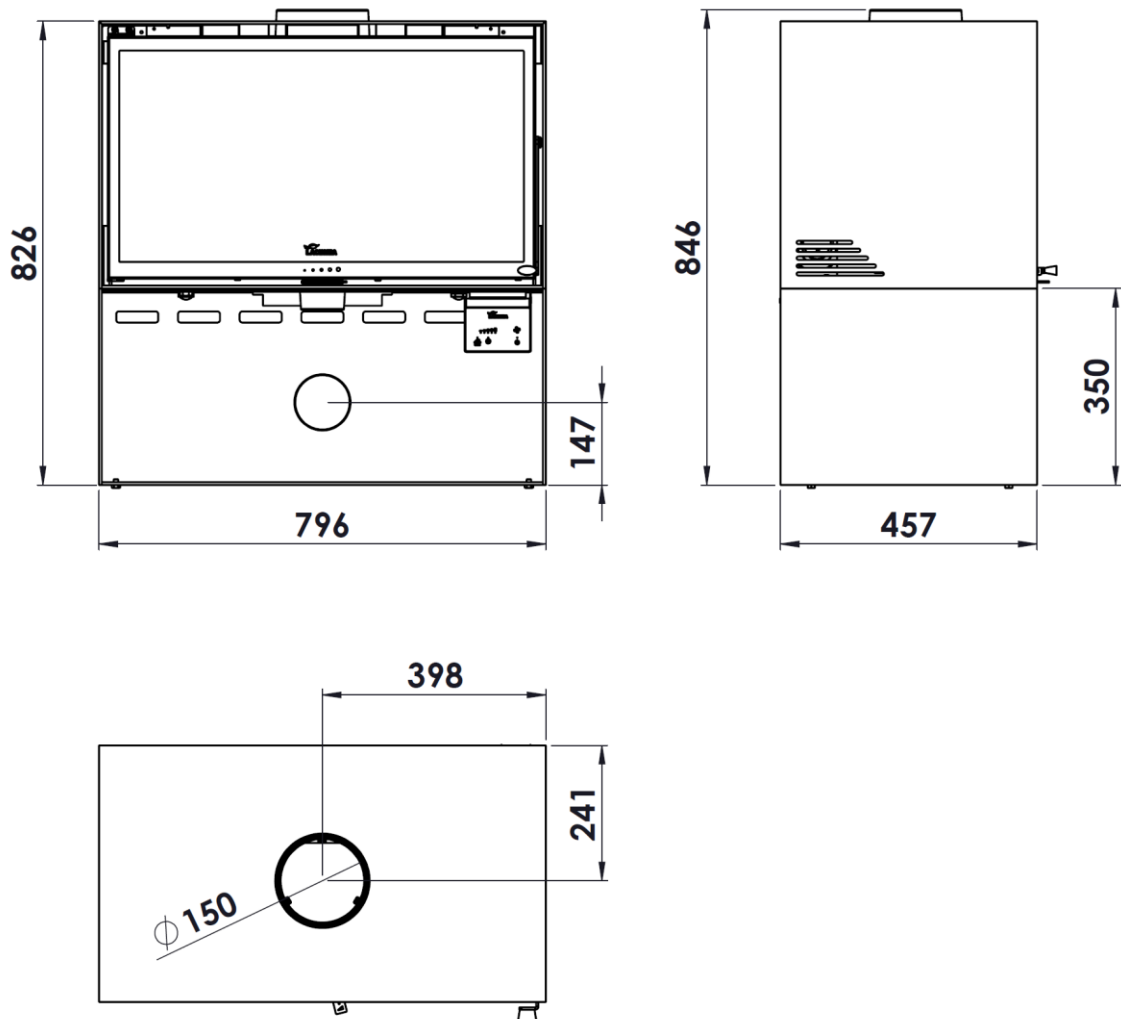


Figure No.5 - Dimensions of the NIVE 800 Free-standing with woodbox

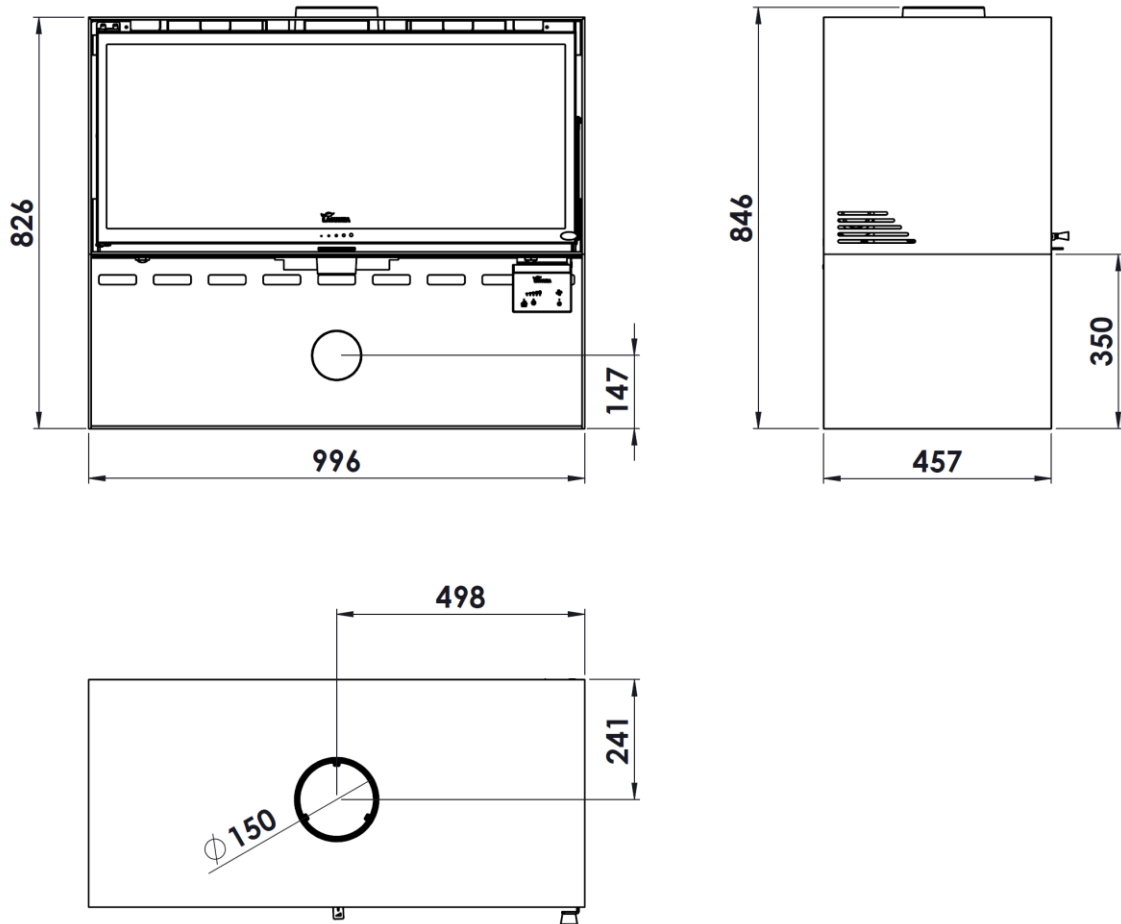


Figure No.6 - Dimensions of the NIVE 1000 Free-standing with woodbox

2. INSTRUCTIONS FOR THE INSTALLER

2.1. Warning to installers

All local and national regulations, including all those referring to national and European standards, must be observed when installing the appliance.

Installation of the appliance must be performed by an authorised installer.

An incorrectly installed appliance may lead to serious incidents (fires, creation of harmful gases, deterioration of nearby fixtures, etc.).

Lacunza's liability is limited to the supply of the material and does not include installation of the appliance.

2.2. Room for installation

This appliance must be installed in compliance with AS/NZS 2918 (or latest version) and all applicable building regulations. Ensure provision of adequate ventilation or external air supply to the room in which the appliance is installed. Insufficient air supply or blockage of the flue may result in inefficient combustion, smoke in the room, elevated emissions and unsafe operation. Use only dry, seasoned wood, and operate the air controls as instructed. Regularly inspect and clean the flue system. Installation and servicing must be carried out by a qualified installer.

2.2.1. Location of the appliance in the room

Choose a location in the room which favours good hot-air distribution by convection and radiation.

2.3. Installation of the appliance

Make sure that the base can withstand the total constructed weight of the appliance and its casing.

When the floor surface (base) is combustible, fit suitable insulation.

2.3.1. Safety distances for freestanding

Be sure to respect the appliance installation distances from **combustible materials**.

NIVE 800

A minimum 1055mm deep x 1110mm wide x 40mm thick floor protector (PROMAFOUR board) should be used under and in front of the appliance base when installing the appliance (see joint AS/NZS 2918:2018 3.3.2). The floor protector should extend 600mm in front of the appliance door and be placed centrally in the 1110mm width. The Thermal resistivity of the floor protector is 0.22m².K/W for 40mm thick PROMAFOUR board sheets.

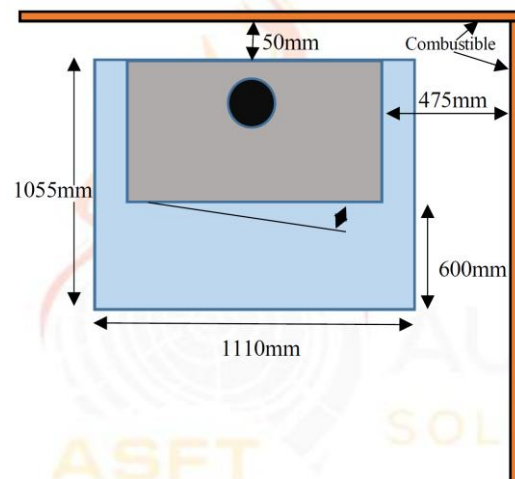


Figure No.7 - Safety distances for Nive 800 free-standing in parallel position

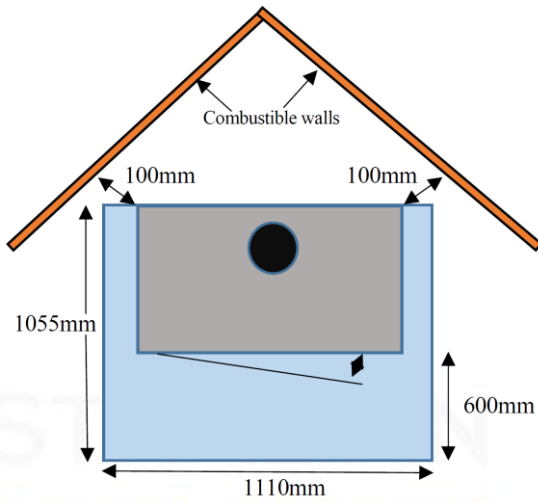


Figure No.8 - Safety distances for Nive 800 free-standing in corner position

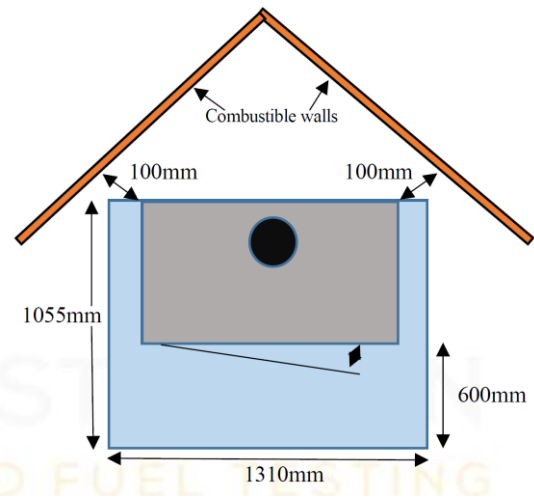


Figure No.10 - Safety distances for Nive 1000 free-standing in corner position

NIVE 1000

A minimum 1055mm deep x 1310mm wide x 40mm thick (PROMAFOUR board) and 9mm thick (compressed board) floor protector should be used under and in front of the appliance base when installing the appliance (see joint AS/NZS 2918:2018 3.3.2). The floor protector should extend 600mm in front of the appliance door and be placed centrally in the 1310mm width. The Thermal resistivity of the floor protector is 0.21m².K/W for 40mm thick PROMAFOUR board sheets, 0.039m².K/W for 9mm thick compressed board sheets.

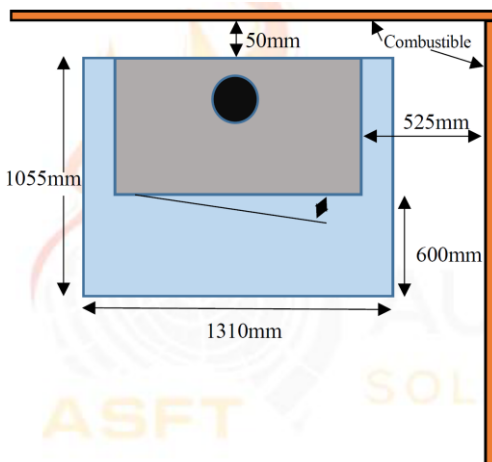


Figure No.9 - Safety distances for Nive 1000 free-standing in parallel position

2.3.2. Elevation clearance

Fireplace base min 300mm off the ground

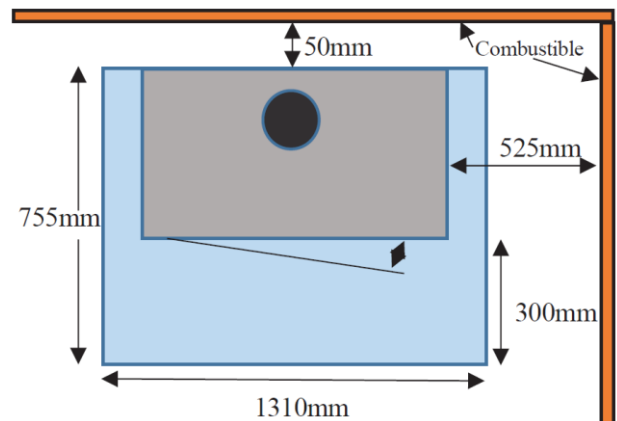


Figure No.11 - Nive Freestanding

NIVE 800 NIVE 1000	Front in m	Thickness in mm
Flat on ground	0.600	50mm
Raised 100	0.565	36mm
Raised 200	0.454	36mm
Raised 300	0.300	18mm
Raised 400	0.300	18mm
Raised 500	0.300	18mm

2.3.3. Safety distances fo in built and zero clearance box

NIVE 800

A minimum 560mm deep x 1260mm wide x 6mm thick floor protector (compressed board) should be used under the appliance base when installing the appliance (see joint AS/NZS 2918:2018 3.3.2). A minimum 915 x 300mm x 6mm thick floor protector (compressed board) should be used in front of the enclosure base. The floor protector should extend 300mm in front of the appliance door and be placed centrally in the 915mm width. The Thermal resistivity of the floor protector is $0.026\text{m}^2\cdot\text{K}/\text{W}$ for 6mm thick compressed cement sheets. The appliance was installed 500mm above the floor protector.

The appliance and flue system were tested at the following clearances:

- Venting in the ceiling of the enclosure around the outer triple flue skin must be a minimum of $305,723\text{mm}^2$, evenly spaced around the outer casing.
- Timber framing in the ceiling cavity must be a minimum of 1325mm above the zero box and must have a minimum $305,723\text{mm}^2$ air flow around the flue outer casing.
- The inner galvanised casing of the flue (203mm) must be vented into the zero-clearance box and be sealed to prevent venting into the enclosure.
- The outer galvanised casing of the flue (254mm) must be raised 65mm above the zero-clearance box.
- The combustible enclosure must have 2 vents, each vent must be 50 high x 200mm wide ($10,000\text{mm}^2$ each vent). The bottom vent must be 50mm above the floor, the top vent must be 500mm below the ceiling. They must be installed on the front of the

combustible enclosure and must be made of a heat resistant material.

- Underside mantel shelf shall be no closer than 440mm from the top of the appliance hot air outlet, the mantel shelf shall extend no further than 250mm into the room.
- Underside mantel key shall be no closer than 390mm from the top of the appliance hot air outlet, the mantel key shall extend no further than 25mm into the room.
- Mantle uprights shall be no closer than 90mm from the side of the appliance fascia and the mantle uprights shall be no thicker than 45mm.
- The front wall of the zero-clearance box enclosure must be made of non-combustible material to a height of 1450mm above the floor protector and must extend 235mm either side of the appliance down to the floor protector on both sides of the enclosure.
- First internal noggin must be a minimum of 300mm above the top of zero clearance box. The Noggin must not be closer than 80mm from the outer flue casing.
- Combustible material to the rear wall of the enclosure must be a minimum of 50mm from the rear of the appliance zero clearance box.
- Combustible material to side walls of the enclosure must be a minimum of 100mm from the side of the appliance zero clearance box.

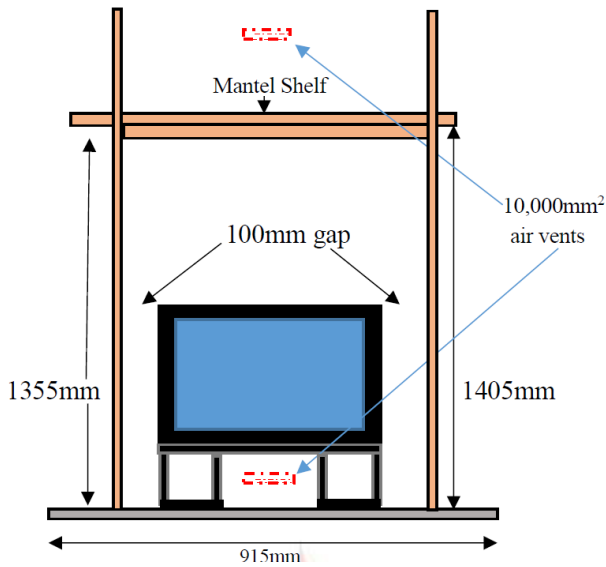


Figure No.12 - Front view of safety distances of Nive 800 inbuilt and zero clearance box

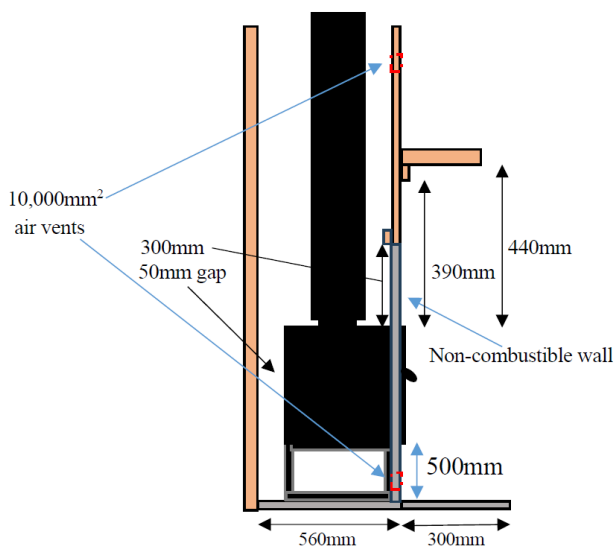


Figure No.13 - Profile view of safety distances of Nive 800 inbuilt and zero clearance box

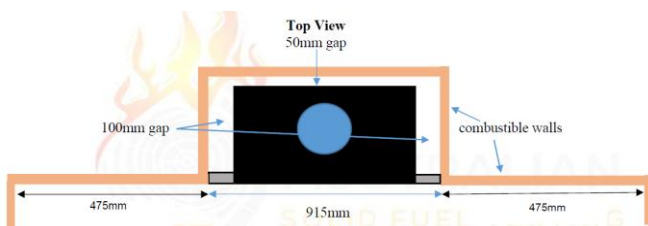


Figure No.14 - Top view of safety distances of Nive 800 inbuilt and zero clearance box

NIVE 1000

A minimum 560mm deep x 1260mm wide x 6mm thick floor protector (compressed board) should be used under the appliance base when installing the appliance (see joint AS/NZS 2918:2018 3.3.2). A minimum 1310 x 300mm x 6mm thick floor protector (compressed board) should be used in front of the enclosure base. The floor protector should extend 300mm in front of the appliance door and be placed centrally in the 1310mm width. The Thermal resistivity of the floor protector is $0.026\text{m}^2\cdot\text{K}/\text{W}$ for 6mm thick compressed cement sheets. The appliance was installed 500mm above the floor protector.

The appliance and flue system were tested at the following clearances:

- Venting in the ceiling of the enclosure around the outer triple flue skin must be a minimum of $305,723\text{mm}^2$, evenly spaced around the outer casing.
- Timber framing in the ceiling cavity must be a minimum of 1325mm above the zero box and must have a minimum $305,723\text{mm}^2$ air flow around the flue outer casing.
- The inner galvanised casing of the flue (203mm) must be vented into the zero-clearance box and be sealed to prevent venting into the enclosure.
- The outer galvanised casing of the flue (254mm) must be raised 65mm above the zero-clearance box.
- The combustible enclosure must have 2 vents, each vent must be 50 high x 200mm wide ($10,000\text{mm}^2$ each vent). The bottom vent must be 50mm above the floor, the top vent must be 500mm below the ceiling. They must be installed on the front of the combustible enclosure and must be made of a heat resistant material.

- Underside mantel shelf shall be no closer than 440mm from the top of the appliance hot air outlet, the mantel shelf shall extend no further than 250mm into the room.

- Underside mantel key shall be no closer than 390mm from the top of the appliance hot air outlet, the mantel key shall extend no further than 25mm into the room.

- Mantle uprights shall be no closer than 100mm from the side of the appliance fascia and the mantle uprights shall be no thicker than 45mm.

- The front wall of the zero-clearance box enclosure must be made of non-combustible material to a height of 1450mm above the floor protector and must extend 135mm either side of the appliance down to the floor protector on both sides of the enclosure.

- First internal noggin must be a minimum of 300mm above the top of zero clearance box. The Noggin must not be closer than 45mm from the outer flue casing.

- The Combustible rear wall of the enclosure must be a minimum of 50mm from the rear of the appliance zero clearance box.

- The Combustible side walls of the enclosure must be a minimum of 100mm from the side of the appliance zero clearance box.

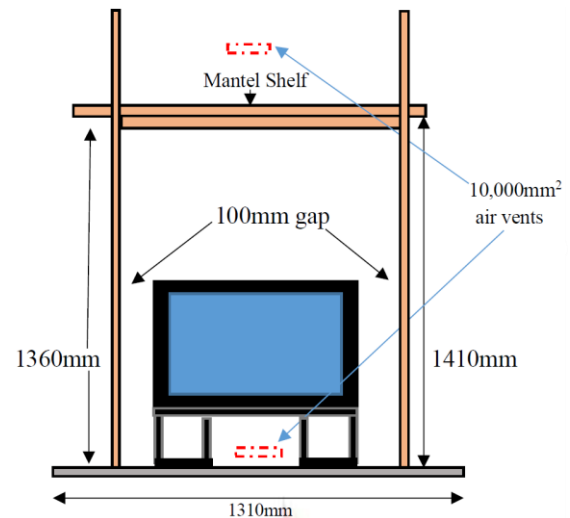


Figure No.15 - Front view of safety distances of Nive 1000 inbuilt and zero clearance box

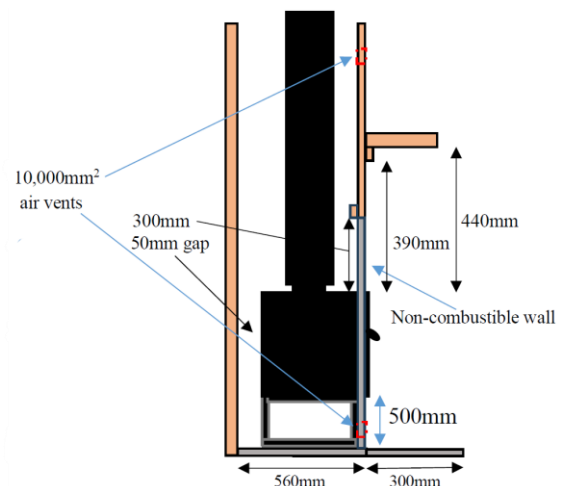


Figure No.16 - Profile view of safety distances of Nive 1000 inbuilt and zero clearance box

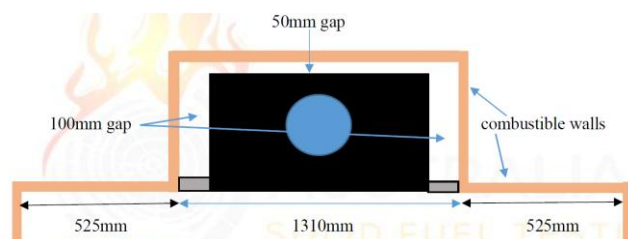


Figure No.17 - Top view of safety distances of Nive 1000 inbuilt and zero clearance box

Bear in mind that it may even be necessary to protect non-combustible material in order to prevent breakage, deformation, etc., as a result of overheating if the non-combustible material is not designed to withstand high temperatures.

2.3.4. Checks before lighting for the first time

- Make sure that the glass is not broken or damaged.
- Make sure that the flueway is not obstructed with packing or loose parts.
- Make sure that the airtight joints on the flue circuit are in perfect condition.
- Make sure that the doors close properly.
- Make sure that all moving parts are fitted in place.
- Check that the deflector is fitted properly

2.3.5. Height adjustment and levelling the appliance

The appliance must be perfectly level, horizontally and vertically, both at the front and on the sides (use a spirit level).

The appliance has adjustable legs with which to adjust its height.

The legs can be adjusted using a 24mm spanner.

2.3.6. Casing

Make sure that the material around the appliance is not flammable or likely to deteriorate as a result of heat (wallpaper, carpet, plastic-based casing, Silestone, etc.).

The image below gives an example of how the appliance can be encased properly:

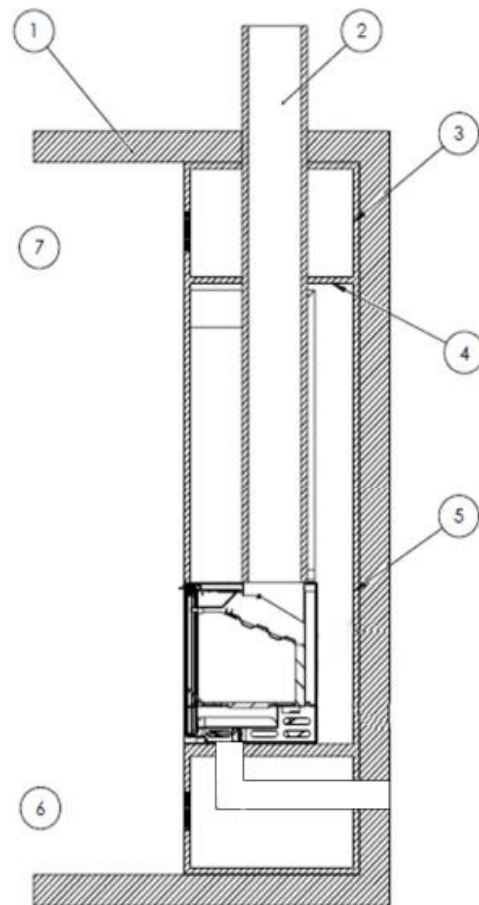


Figure No.18 - Interior diagram of the casing

Key to casing diagram:

- 1 Ceiling
- 2 Flue
- 3 Incombustible material (Inner hood insulation)
- 4 Insulating deflector made of incombustible material
- 5 Wall
- 6 Fresh-air inlet (9820 cm²)
- 7 Hot-air outlet (9820 cm²)

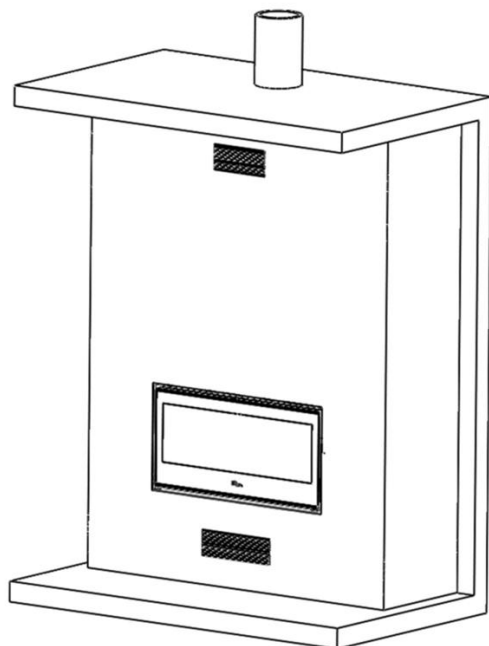


Figure No.19 - Exterior diagram of the casing

In order to enable suitable air circulation and correct operation, the casing must have a fresh-air inlet with a minimum section of $1,000\text{cm}^2$ beneath the level of the actual appliance and a hot-air outlet measuring at least $1,250\text{cm}^2$ above it (just before the insulating deflector inside the casing). These inlet and outlet sections must ensure air renewal in such a way as to avoid damage to parts inside the hood due to excess temperature.

This specification must be observed regardless of the type of installation chosen (with or without forced ventilation, combustion air from indoors or outdoors, directed hot-air outlets with or without pipes, etc.). A further hot-air ventilation grille is also recommended between the insulating deflector on the hood and the ceiling.

As well as this, the hood/closure should have a free opening of at least 100 cm^2 for the intake of air for combustion.

Warning: on appliances on which it is possible to pipe air to the firebox, the hood

requires a further air inlet at the bottom, in addition to the $1,000\text{cm}^2$ inlet, if the air supply comes from the room in which the appliance is fitted.

On non-central-heating appliances (without back boiler), Lacunza does not recommend enveloping the outside of appliances with insulation.

Never completely block off the lateral ventilation grilles of the fairing.

The installer must fit the necessary inspection accesses (trap doors, hatches, etc.) so that everything inside the hood that may need maintenance work, cleaning or replacement can be accessed at any time.

2.3.7. Preparing the outside air connection

On this model, it is possible to pipe air to the appliance for combustion straight from outdoors. We recommend that, if possible, air be drawn from outdoors for combustion via a non-closable pipe with a diameter of 80mm leading to the nozzle on the bottom-front of the appliance.

If the tube is straight, it can have a maximum of 12 meters in length. If you use accessories like elbows, you must subtract the total length (12 meters) 1 meter for each accessory used.

This is the best option because it means that draughts are not created in and oxygen is not consumed from the room in which the appliance is fitted. A further advantage is that there is no danger of downdraught which may hinder the correct updraught of the appliance when an extractor or mechanical ventilation appliance is used in the same room as the central-heating appliance or in another one alongside it.

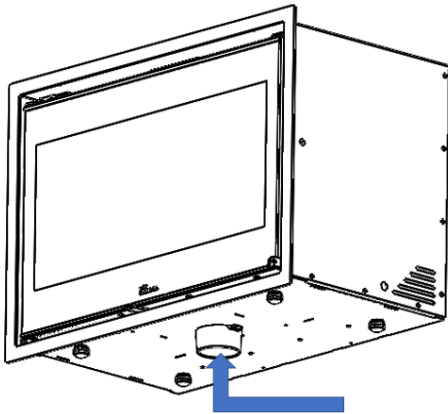


Figure No.20 - Air conduction for the combustion chamber

If this is not possible, ensure that the appliance receives air for combustion.

The device has an **accessory** to channel the air inlet from the rear. This accessory is **NOT** shipped as standard with the device.

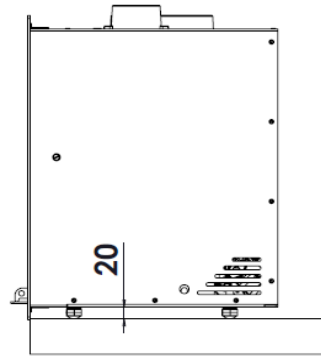


Figure No.21 - **Accessory** to channel the air inlet from the rear

Outside air connection via the wall

1. Make an opening in the wall (see the measurements of the appliance on the section 1.1 to see the exact position of the hole).
2. Close the air connection hermetically to the wall.

Attention: The legs that ensure the proper distance between the base and the appliance can not be removed. This must be greater than 20 mm.



2.3.8. Connection to the flue

The appliance must be connected to the chimney flue using special piping designed to resist the products of combustion (e.g. stainless steel, enamelled steel, etc.).

To connect the flue to the socket flange, insert the piping inside the flange and seal the joint with fire sealant or fire cement to make it completely airtight.

The installer must ensure that the pipe connected to the appliance is well secured and there is no chance of it coming free from its housing (e.g. as a result of dilatation due to temperature, etc.).

On this appliance, the flue socket can be fitted on top of the appliance.

2.3.9. Piping air to other rooms (only for Nive version with fan installed, not for Nive F)

It is possible to pipe some of the heat generated to other rooms in the house using the appliance. This does not mean that the appliance works more efficiently, but it does mean that the heat it creates is distributed better. For this purpose, in the top surface of the appliance there are 2 potential hot-air outlets with diameters of 120mm on the top shell of the appliance. Pipes can be fitted from these outlets to other rooms. If you intend to do this, bear the following points in mind.

- The air ducts must always be heat insulated and smooth inside (not corrugated).
- The pipes must always have an upward slant to facilitate movement by air density.
- On routes with a lot of load loss (a lot of retention), air movement can be forced along the ducts using a motor or fan, provided that it is designed to withstand such temperature conditions.

Bear in mind that air ducts mean that noise travels more easily from one room to another.

The following table shows the heat output of the air from the hot-air outlets with the appliance working at Nominal Heat Output:

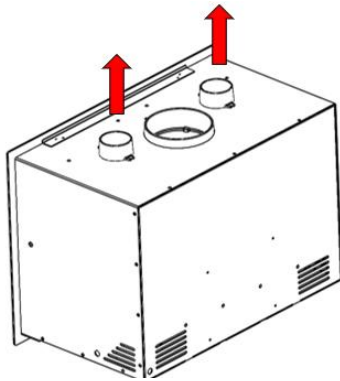


Figure No.22 - Nive 800

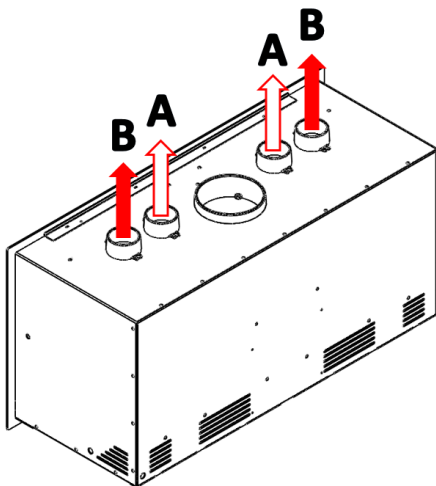


Figure No.23 - Loire 1000

		Output (kW)
NIVE 700		0.8
NIVE 800		0.8
NIVE 1000	A	0.6
	B	0.9

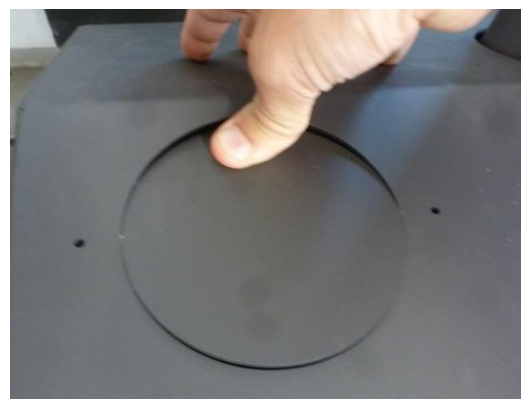
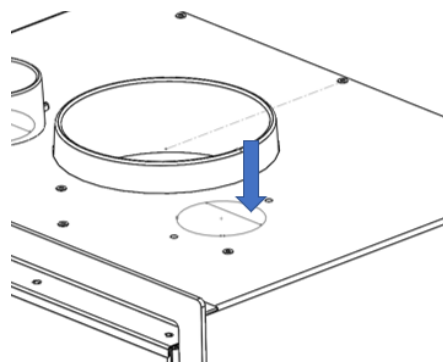
Figure No.24 - Table showing heat output of the air leaving the appliance

Note: The values shown in the above table were measured at the appliance output point and based on tests performed at nominal heat output and maximum fan speed.

All hot-air ducts lose heat, meaning that the heat output obtained at the end of piping always depends on its design.

The appliance NIVE there are 2 potential hot-air outlets with diameters of 80 mm on the top shell of the appliance.

1° Turn the piece from the back of the circle as seen in the images.



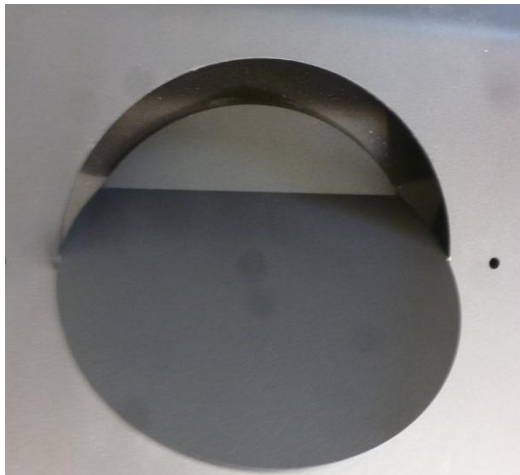
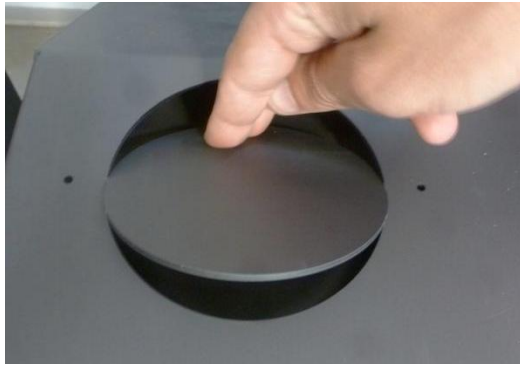


Figure No.25 - Push as indicated by arrow

This favors the movement of air into the air outlet

2° Place the nozzle into position.

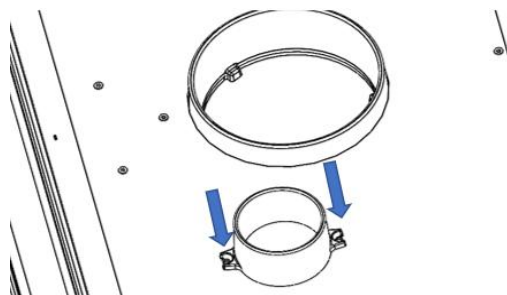


Figure No.26 - Screw the nozzle.

2.3.10. Exterior Frame. Removal and assembly (only for Nive version, not for Nive F)

To fit the frame, proceed as follows:

- Bend all the tabs located in the upper and lower part of the frame, as shown in the picture.

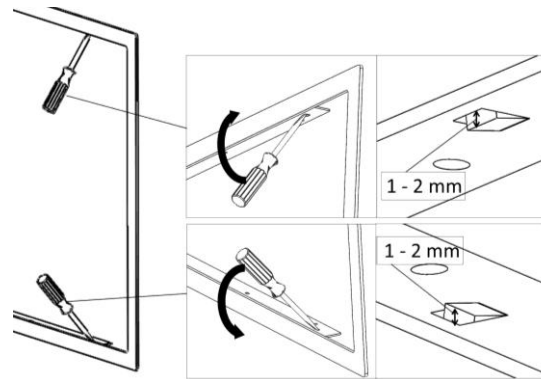


Figure No.27 - Bending the tabs

- Insert the frame in the appliance pressing.

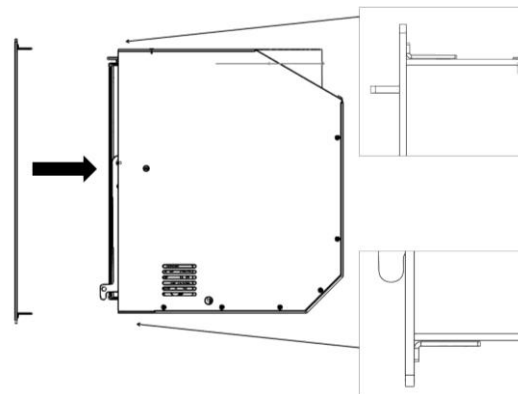


Figure No.28 - Insert frame in the appliance

- To remove the frame, perform the same operation in reverse order.

2.3.11. Turbine-potentiometer connection (Only for models with fan installed)

These are the connection instructions in order to control the ventilator system using the supplied potentiometer.

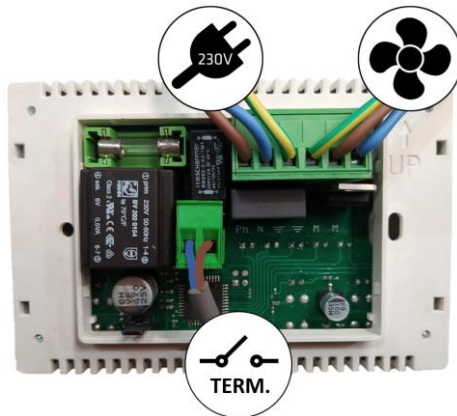


Figure No.29 - Connections to be carried out in the potentiometer

WARNING: the operating temperature of the potentiometer supplied by Lacunza is from 0 to 40°C. Particular care should be taken when choosing where it will be positioned so that it is not damaged by temperatures above 40°C. Insulate the potentiometer correctly so as to avoid this problem.

Read the potentiometer instruction manual.

2.1. Masonry section

The Unit when referring to installation into Masonry should allow 50mm air gap around the unit sides and rear to allow for Thermal expansion.
It is recommended to vent where possible below and above the unit.

AS/NZS 2918:2018

Masonry: A bonded construction using clay bricks, concrete bricks or blocks, pumice concrete, sand-lime bricks, square-dressed natural stone, terracotta, or similar materials laid manually unit by unit and set in mortar.

Masonry chimney: A masonry structure, usually vertical, containing a passage or flue through which smoke, gases, and other products of combustion from a fire

are carried to the outside of a building and by means of which a draught is created to assist combustion.

Masonry enclosure: An open-fronted masonry structure not incorporating an integral masonry chimney, originally designed to surround a solid-fueled cooking and/or heating appliance.

Masonry fireplace: A fireplace constructed from masonry materials.

Masonry recess: A construction of masonry materials designed for use as a surround or recess for the installation of a freestanding domestic solid fuel burning appliance.

Open-vented hot-water system: A hot-water system that has an unobstructed vent to the atmosphere, with the highest point of the vent no greater than 5 m above the lowest point of the system.

Penetrations

Flat ceiling penetration: Where the angle (slope) of the ceiling is 30° or less from the horizontal plane.

Sloped ceiling penetration

Where the angle (slope) of the ceiling is greater than 30° but less than 60° from the horizontal plane.

Wall penetration: Where the angle (slope) of the wall or ceiling is between 60° and 90° from the horizontal plane.

2.2. Chimney flue

The chimney flue must comply with present standards on the installation of chimneys.

In rooms equipped with Controlled Mechanical Ventilation, the ventilation outlet must never be connected to the flue.

The appliance must always have its own chimney flue, never sharing a chimney flue with another appliance.

2.2.1. Type of flue

NIVE 800 FREE-STANDING

The flue system used during testing was a 6" triple skin Flue Kit with 8" solid casing. This flue system conforms to the requirements of joint AS/NZS 2918:2018, Appendix F. The flue height was 4.6 ± 0.1 m from the floor protector.

NIVE 1000 FREE-STANDING

The flue system used during testing was a 6" triple skin Flue Kit with 8" solid casing. This flue system conforms to the requirements of joint AS/NZS 2918:2018, Appendix F. The flue height was 4.6 ± 0.1 m from the floor protector.

NIVE 800 INBUILT AND ZERO CLEARANCE BOX

The flue system used during testing was a 6" triple skin flue kit incorporating 8" Inner galvanised casing vented into the zero clearance box and a 10" outer casing raised 65mm above the zero clearance box. This flue system has not been tested to joint AS/NZS 2918:2018, Appendix F. The flue height was 4.6 ± 0.1 m from the floor protector.

NIVE 1000 INBUILT AND ZERO CLEARANCE BOX

The flue system used during testing was a 6" triple skin flue kit incorporating 8" Inner galvanised casing vented into the zero clearance box and a 10" outer casing raised 65mm above the zero clearance box. This flue system has not been tested to joint AS/NZS 2918:2018, Appendix F. The flue height was 4.6 ± 0.1 m from the floor protector. Appendix 1 shows details of the flue system.

The flue must be made of special material designed to resist the products of combustion (e.g. stainless steel, enamelled steel, etc.).

If the chimney is constructed, then it is necessary to pipe and insulate it to ensure correct updraught.

The diameter of the pipe must be the same as the diameter of the flue socket on the appliance over its entire length in order to ensure correct operation.

The flue must prevent the entry of rainwater.

The flue must be clean and airtight over its entire length.

It's highly recommended that the flue is a minimum of 5 meters high. Less than 5 meters could result in the fireplace not operating correctly. and the chimney cap must not hinder the free release of gases.

If the flue tends to suffer from downdraught, then it is necessary to fit an effective anti-downdraught cowl, a static cowl or a smoke extraction fan, or reshape the chimney.

Never make 90° bends, due to the great loss of draught they cause, and reduce 45° bends down to an absolute minimum. Each 45° bend is equivalent to a 0.5m reduction in flue length. Horizontal flue sections should not be installed because they cut updraught a great deal.

The appliance is designed to operate under controlled draught conditions. The appliance must operate at a chimney draught of between 12Pa and 15Pa. To ensure this draught, an automatic draught moderator must be installed in the flue. Uncontrolled draught operation can lead to quick damage of the appliance, which will not be covered by the warranty.

The flue must not rest its weight on the appliance, as this could damage the worktop.

Bear in mind that high temperatures may be reached in the flue, meaning that it is essential that insulation be enhanced in sections in which combustible material is present (wooden beams, furniture, etc.).

It may even be necessary to protect non-combustible material in order to prevent breakage, deformation, etc., as a result of overheating if the material is not designed to withstand high temperatures.

It must be possible to clean the entire flue, no sections being left inaccessible for cleaning purposes.

2.2.2. Chimney crown

Minimum bending length: Refer to the standard to be tested in accordance with appendix F of AS/NZS 2918.

The upper end of the chimney must clear the roof, the roof ridge or any obstacle located on the roof by at least 1m.

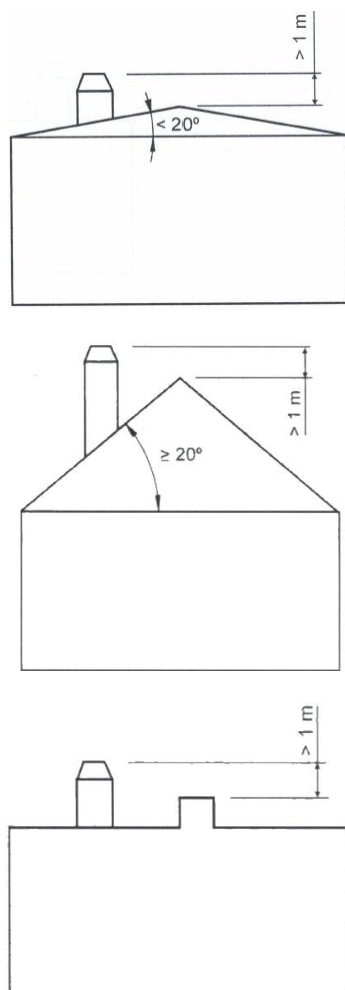


Figure No.30 - Distances between chimney crown and roof ridge

The chimney crown must clear the highest point of any neighbouring building or obstacle located within a 10m radius of the chimney outlet by more than 1m.

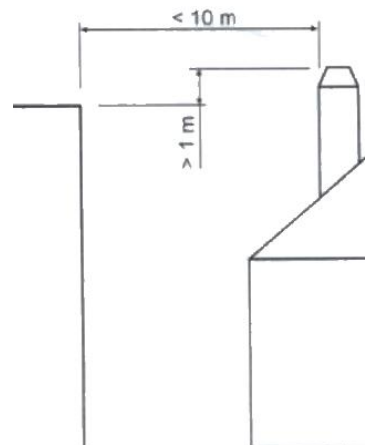


Figure No.31 - Distances between the chimney crown and objects within a 10m radius

The chimney crown must clear any neighbouring building or obstacle located within a radius of 10m to 20m from the chimney outlet.

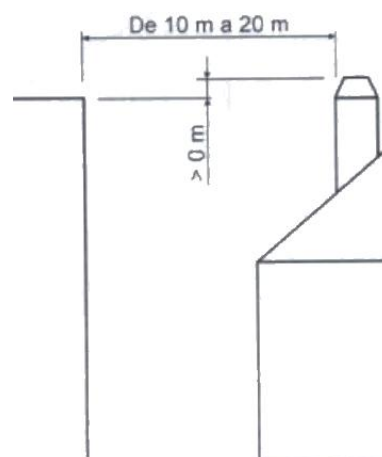


Figure No.32 - Distances between the chimney crown and objects within a radius of between 10 and 20m

3. INSTRUCTIONS OF USE

The manufacturer accepts no liability whatsoever for damage caused to parts as a result of the improper use of non-recommended fuels, modifications made to the appliance or how it is installed.
Only use original replacement parts.

All local and national regulations, including those referring to national and European standards, must be observed when using the appliance.

Heat is diffused by radiation and convection via the front and exterior of the appliance.

3.1. Fuel

This appliance must not be used as an incinerator. Do not use non-recommended fuels.

- Use dry logs (max. 16% humidity), cut at least 2 years ago, clean of resin and stored in a sheltered, ventilated place.
- Use hard woods with high calorie values and good ember production.
- Large logs should be cut to useable lengths before being stored. The logs should have a maximum diameter of 150mm.
- Finely-chopped wood produces greater heat output, but also burns more quickly.

Optimum fuels:

- Beech, hardwood and eucalyptus logs.

Other fuels:

- Oak, chestnut, ash, maple, birch, elm, etc.
- Pine and eucalyptus logs are low density and produce very long flames, and may cause the parts of the

appliance to wear out more quickly than normal.

- Resinous wood may mean that the appliance and the flue need to be cleaned more often.

Non-permitted fuels:

- All types of coal and liquid fuel.
- “Green wood”. Green or damp wood reduces the performance of the appliance and leads to soot and tar build-up on the inner walls of the flue, obstructing it.
- “Recovered wood”. The burning of treated woods (railway sleepers, telegraph posts, plywood, fibreboard, pallets, etc.) quickly blocks the system (soot and tar build-up), harms the environment (pollution, smells) and may lead to deformation of the firebox due to overheating.
- All materials which are not wood (plastic, spray cans, etc.).
- Never use gasoline, gasoline-type lamp fuel, paraffin, charcoal lighter fluid, ethyl alcohol or similar liquids to ignite or rekindle a fire in the equipment. Keep all such liquids away from the equipment while it is in use.

Green and reprocessed wood may cause chimney fires.

The graph below shows how the humidity of firewood affects its heat output:

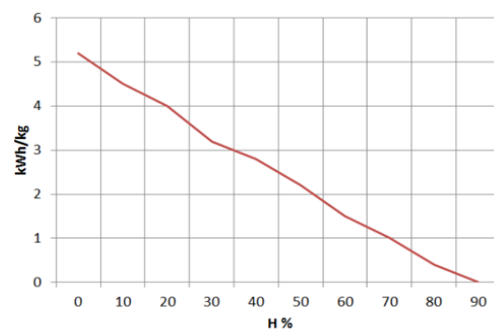


Figure No.33 - Relationship between firewood humidity and heat output.

3.2. Description of the parts of the appliance

3.2.1. Operating components

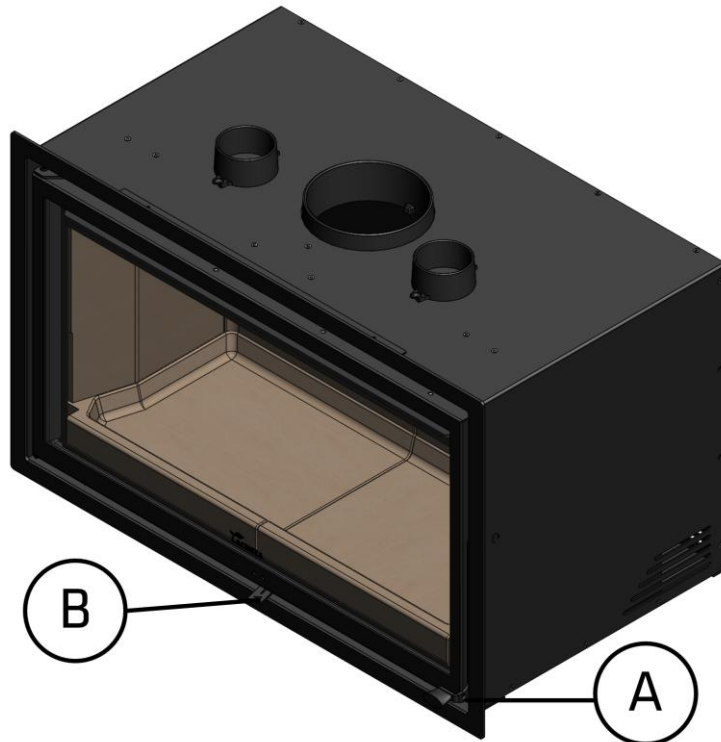


Figure No.34 - *Operating components on the appliance*

- A: Firebox door handle
- B: Air intake
 - B1 Closed (left)
 - B2 Opened (right)

3.3. Lighting

Use of the appliance in warm weather (warm days, early hours of the afternoon on sunny days) may lead to lighting and updraught problems.

Certain weather conditions, such as fog, ice, humidity entering the flue, etc., may hinder sufficient updraught in the flue and lead to suffocation.

Proceed as follows in order to light the appliance satisfactorily:

- Open the firebox door(s) and open all the firebox air-intake inlets to the full.
- Place paper or a firelighter and some wood chips in the firebox.
- Light the paper or firelighter.
- Leave the door slightly ajar, the width of two or three fingers, for about 15 minutes until the glass warms up.
- The first ignition must be soft, to allow the different parts that compose the appliance to expand and dry.

Caution: On first switch-on, the appliance may produce smoke and smell. Do not be alarmed and open a window to the outside to air the room during the first hours of operation.

If you notice water around the appliance, this is caused by condensation from the humidity in the wood when the fire is started. This condensation will cease after three or four ignitions when the appliance is adapted to its flue. If this is not the case, the flue should be checked (length and diameter of the chimney, chimney insulation, tightness) or the humidity of the wood used.

3.4. Loading fuel

In order to load firewood, open the firebox door gently, preventing the sudden entry of air to the firebox so that smoke

does not enter the room that the appliance is installed in. Perform this operation with the glove to prevent burns to the hands.

The maximum height of the load shall be approximately one third of the height of the firebox.

The minimum interval between loads for nominal heat output is 60 minutes.

Always load with the nominal amount (see table in section 1.1).

For minimum burning (e.g. at night), use thicker logs.

When the firebox is loaded, close the door.

Be careful when placing logs in the firebox on appliances with vermiculite interiors. Vermiculite is a fragile material and may crack if knocked. The use of wood with non-recommended humidity levels will quickly damage the vermiculite parts.

3.5. Operation

The appliance should be operated with the door closed.

For safety reasons, never close all the appliance's combustion-air intakes.

Regulation of the air intake for combustion

The appliance is equipped with a single control to regulate the secondary and double combustion air intake.

By opening this register, we introduce air into the combustion chamber through the upper part of the firebox door and through the double combustion holes at the back of the firebox.

Air inlet register

By opening this register, we introduce air into the combustion chamber through the upper part of the firebox door and into the combustion flame, generating a mor

efficient and less polluting combustion, as we carry out a post-combustion by burning the particles burnt in the first combustion. In this way we increase the appliance's efficiency and reduce emissions.

IMPORTANT: By keeping this register open, we will delay the soiling of the glass of the fireplace.

In order to obtain maximum output, open the air intake to the firebox and in order to obtain minimum output, tend towards closing it. For normal use, we recommend to keep the air intake open at 45%.

IMPORTANT: The appliance is exposed to extreme changes in temperature and may, as a result, make noises when in operation. These noises are a natural result of expansion/contraction of the parts which make up the appliance. Do not be alarmed by noises of this kind.

In class B or BE appliances (without combustion air ducting from the street), when the appliance is not in use, the appliance-flue duct assembly may represent a heat leakage route to the street. When the appliance is not in use, it is advisable to leave the air inlet registers to the combustion chamber closed to minimise these energy losses.

3.6. Removing ash

Following sustained use of the appliance, it is necessary to remove the ash from the firebox.

Never throw hot embers into the rubbish.

3.7. Deflectors

The appliance has 2 deflectors.

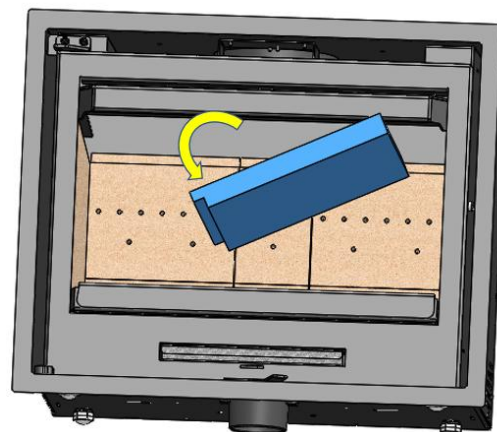
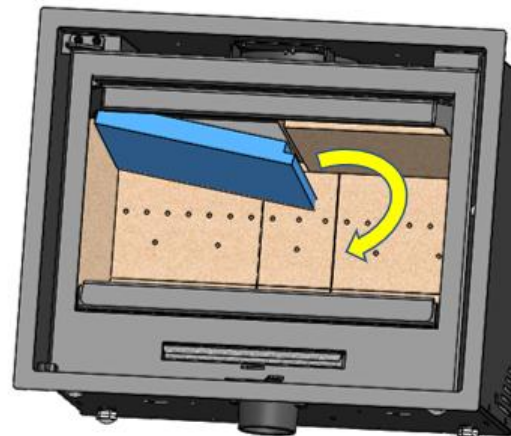
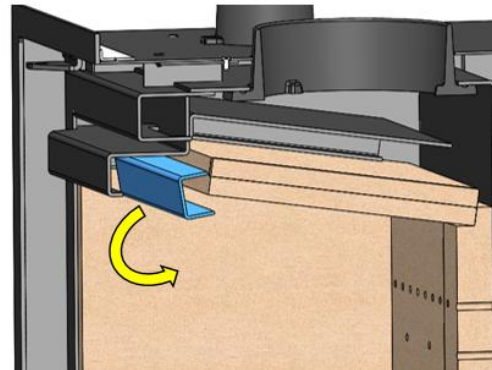


Figure No.35 - Dismantling the NIVE vermiculite deflector

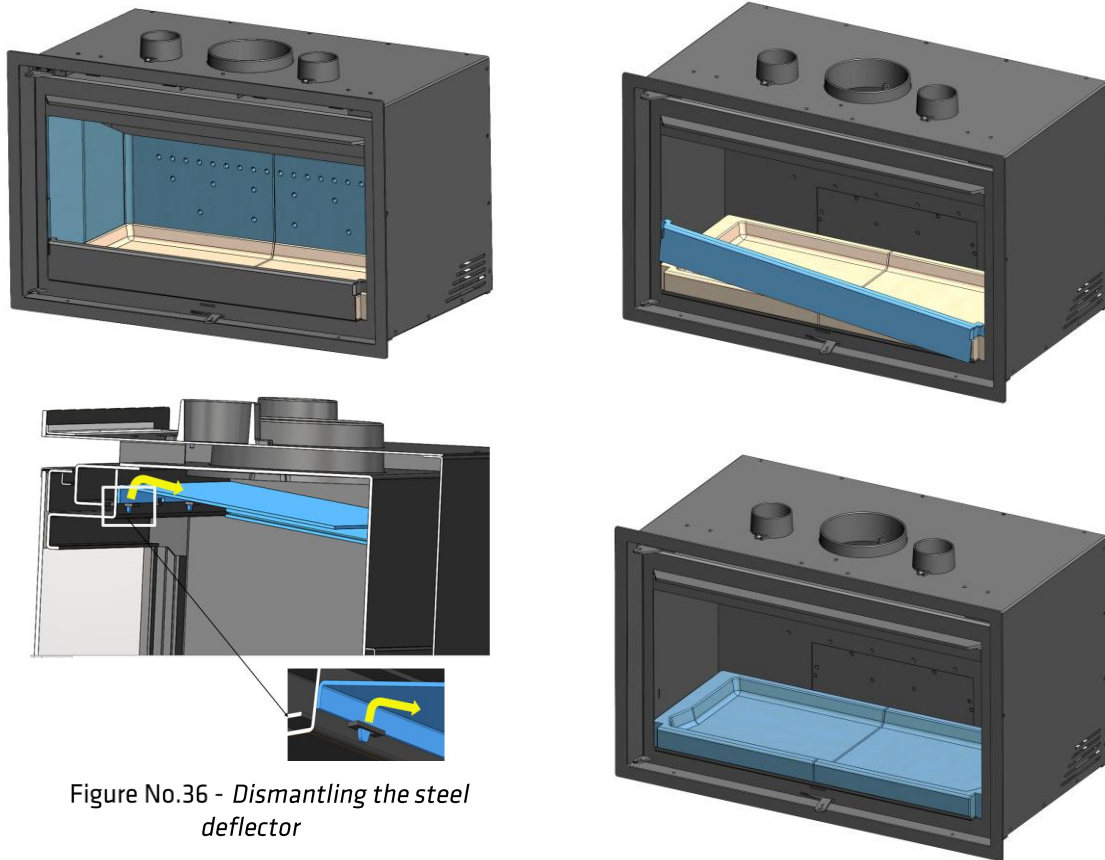


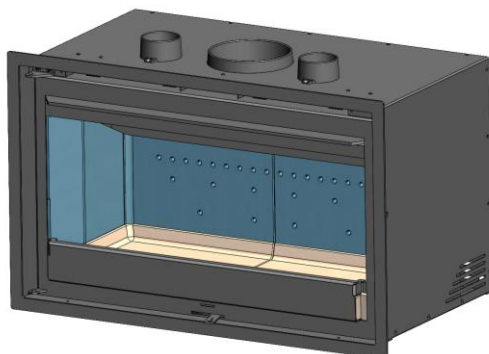
Figure No.36 - Dismantling the steel deflector

3.8. Electrical system

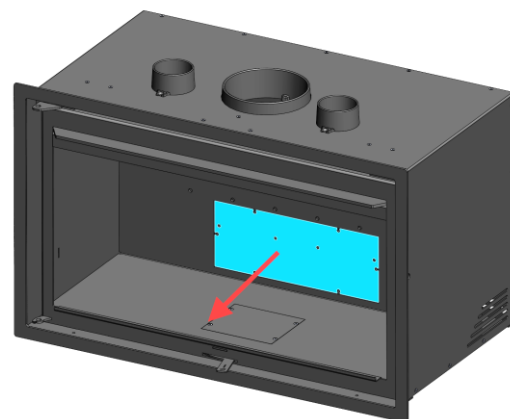
The electrical system is not included as a standard feature. If you require it, you must perform the installation.

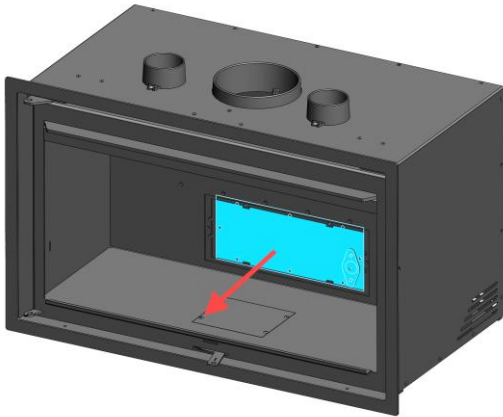
To complete the installation, follow the steps outlined below:

1. Remove the vermiculite deflector following the steps from the previous point.
2. Remove all the vermiculite parts and the steel separator.

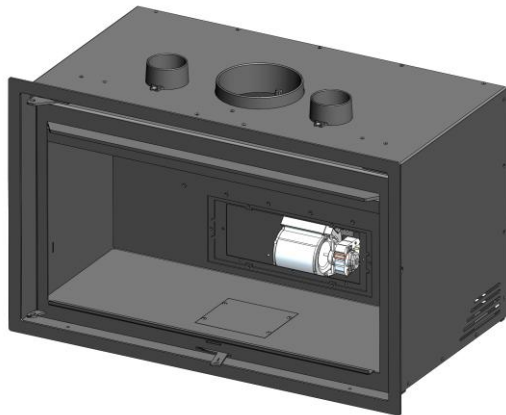


3. Remove two steel covers:





4. Install the fan and the thermostat with their corresponding wiring.



Forced convection. Fans

NIVE 800 has 1 fan (NIVE 1000 3 fans) for the forced convection of the hot air generated around the appliance inside the shell. This air can be piped to other rooms.

IMPORTANT: This appliance is not covered by our warranty unless directly connected to the mains electricity supply in accordance with the conditions described in the relevant section in 1.1.

Potentiometer operation:

By means of its rotating lever, the potentiometer controls the flow of hot-air output from the appliance in two ways:

- **Operation:**

The fan automatically or manually starts working at the set speed. When the fan is working automatically

(recommended), when a fire has been lit in the firebox and the thermostat reaches a temperature of approximately 50°C, the fan starts working at the power set on the potentiometer (rotating wheel) and stops automatically when the temperature drops beneath 50°C.

In addition, we have the option to stop the turbines from the Stop button, whenever we want.



The Potentiometer comes with a remote control, which allows the same operations as the potentiometer.

The remote control of some TV brands may interfere with the potentiometer sensor and change its operation. To avoid possible interference, it is recommended to place the potentiometer in a place away from the TV.

For more information see the potentiometer instruction manual.

4. MAINTENANCE AND IMPORTANT ADVICE

4.1. Maintenance of the appliance

The appliance, the flue connector piping and the flue must be cleaned regularly, particularly following long periods without use.

4.1.1. Firebox

Clean the firebox area of ash, etc.

4.1.2. Inside the appliance

Clean the firebox area of ash. Clean the deflectors, where soot may build up.

4.1.3. Flue socket

The flue socket area must be kept clean at all times for the appliance to work properly.

It must be cleaned as often as required. How often it is cleaned depends on how much the appliance is used and the type of fuel employed.

4.1.4. Firebox glass

To keep the glass as clean as possible for as long as possible, the secondary air register should be kept open. However, over the hours of use, the glass may become dirty. To clean it, we will use specific degreasing products or dry-cleaning products for this task.

The cleaning should be carried out with the glass cold and taking care not to apply the glass cleaner directly on the glass as, if it comes into contact with the door's closing cord, it may deteriorate. Put the cleaning product on the cloth.

It is also important to prevent the cleaning liquid from getting into the moving mechanism of the register, as this could jam it.

Note: If we use the appliance in draught conditions higher than 15Pa or burn more wood (per hour) than those indicated in table 1.1, we will subject the appliance to working conditions higher than those designed for it. This can lead to aggressive fouling of the glass (white halo), which cannot be cleaned by the traditional method.

Caution, the vitro ceramic glass is prepared to support 700°C. Never let burning woods or combustion flame beating against the glass for prolonged periods of time. In this case, the glass would be submit to temperatures above 750°C, this could change the internal structure of the glass and make it opaque (irreversible phenomenon).

4.1.5. Painted sheet-steel-cast-iron parts.

These parts should be cleaned with a brush or dry cloth. Do not dampen the parts: the steel could rust and the paint could blister and chip. Be particularly careful when cleaning the glass: the liquids used must not dampen the painted steel.

4.1.6. Electrical system

The electrical system should be cleaned-vacuumed regularly (depending on the installation and use), so as to avoid the accumulation of ash, lint and other remains that may generate strange noises and/or deteriorate the ventilators and electrical system. Disconnect the electrical network system to perform this task.

Cleaning the electrical system:

Remove the inside of the appliance as indicated in section 3.7.

Release the two inner covers and access the fans as explained in section 3.8.

4.1.7. Air intake registers

In the air intake for combustion registers, remains of ash, sawdust,



cleaning fluids, etc. may accumulate, which restrict or hinder its movement. In these cases, they should be released and cleaned.

4.2. Maintenance of the chimney flue

VERY IMPORTANT: In order to avoid incidents (chimney fires, etc.), it is necessary to perform maintenance and cleaning operations on a regular basis; if the appliance is used often, then the chimney and the flue connector piping must be swept several times a year.

In the event of fire in the chimney, close the flue draught, close doors and windows, remove embers from the firebox,

block the connection hole with damp cloths and call the fire brigade.

4.3. Important advice

Lacunza recommends that only Lacunza-authorized replacement parts be used.

Lacunza accepts no liability for any modification to the product which it has not authorized.







This appliance is a heat-producing appliance and contact may lead to burns.

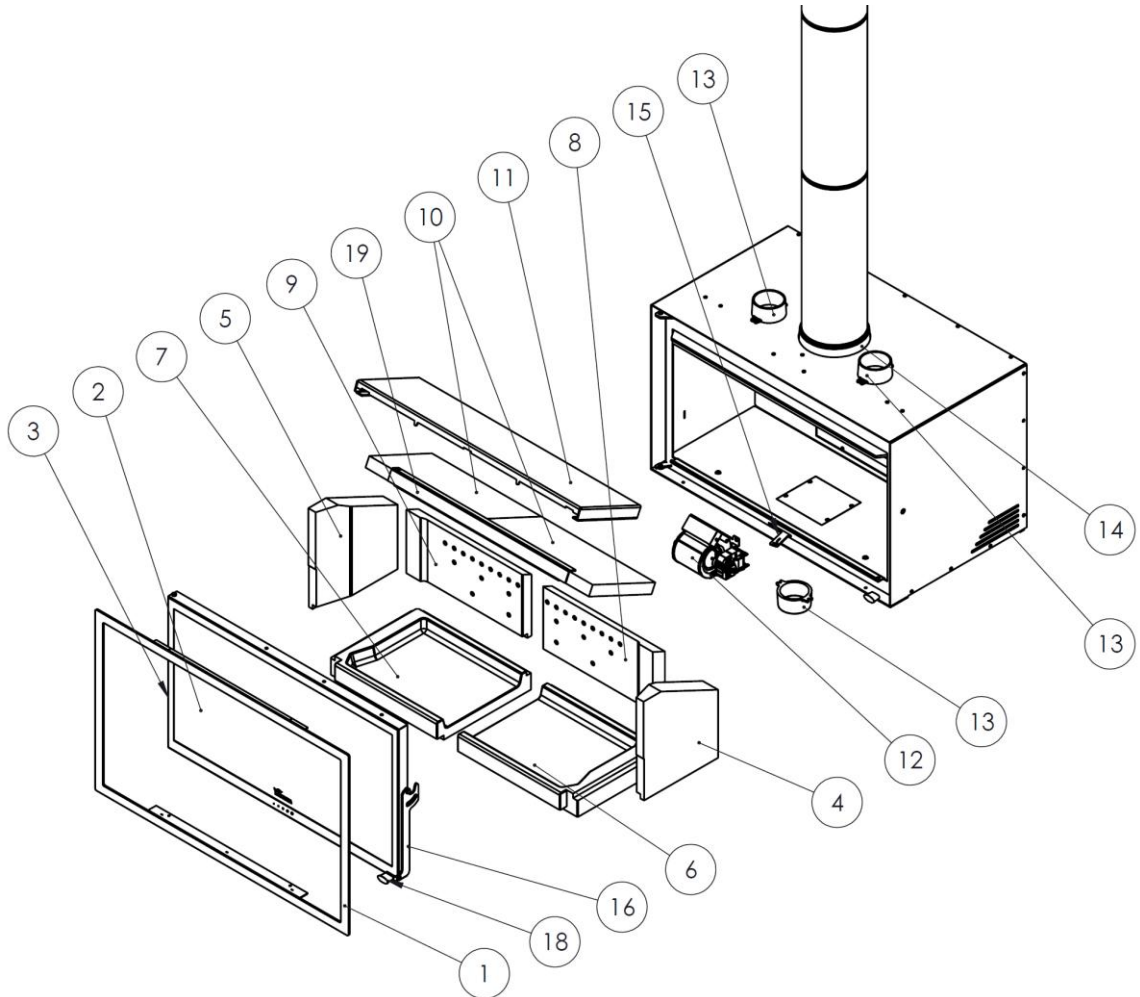
<p>This appliance may remain HOT for a period of time after it has gone out. MAKE SURE THAT SMALL CHILDREN DO NOT GO NEAR IT.</p>

5. TROUBLESHOOTING

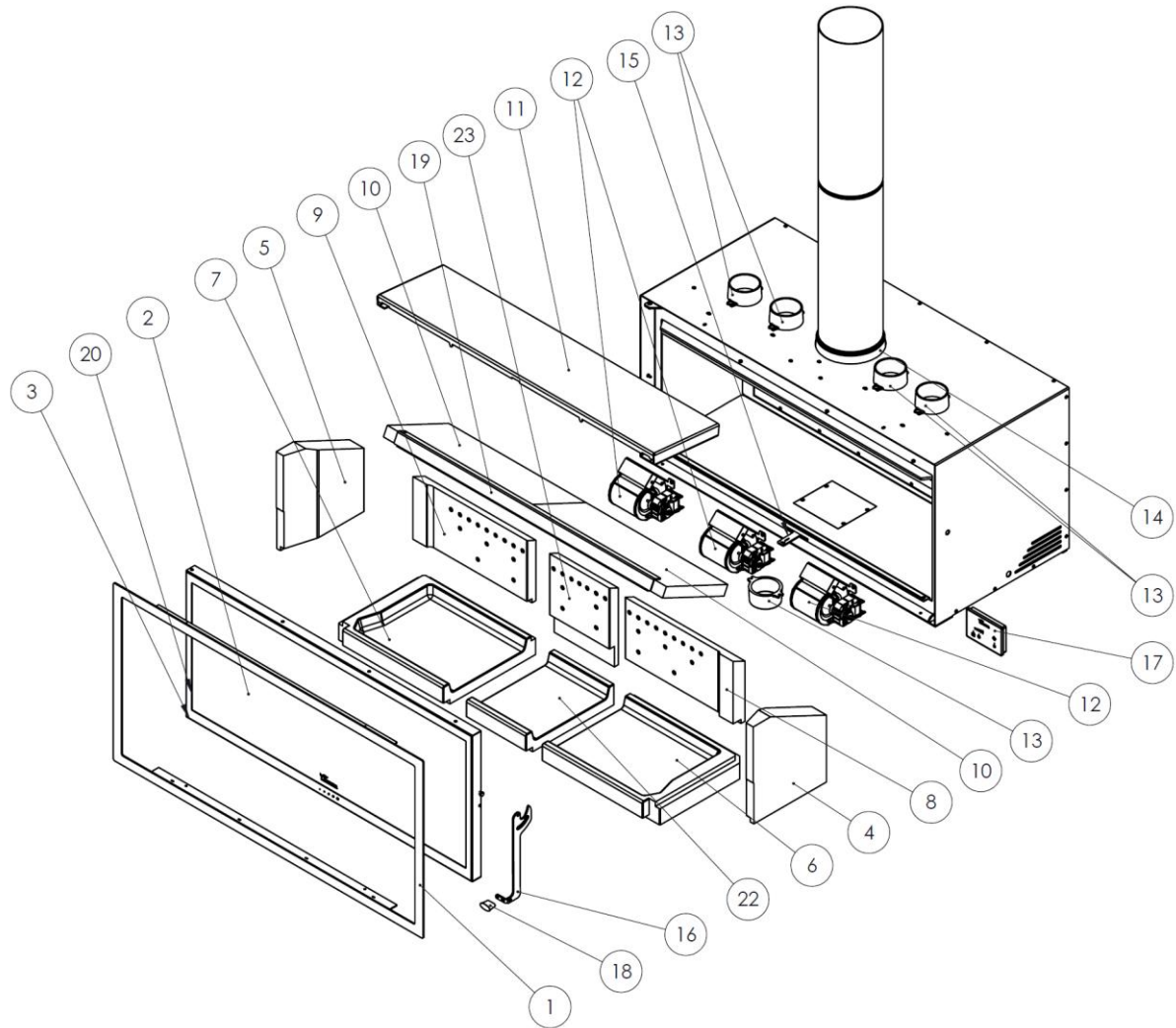


This symbol means that a qualified professional should be called to perform the operation.

Problem	Probable causes		Solution
The fire does not light properly The fire does not stay alight	Green or damp wood		Use hard woods, cut at least 2 years ago and stored in a sheltered, ventilated place
	The logs are too large		Use crumpled paper or firelighters and dry wood chips to light the fire. Use split logs to keep the fire going
	Poor-quality wood		Use hard woods which produce heat and embers (chestnut, ash, maple, birch, elm, beech, etc.)
	Insufficient primary air		Open the primary- and secondary-air intakes completely, or even open the door slightly. Open the outdoor-air inlet grille
	Insufficient updraught		Check that the draught is not blocked. De-soot if necessary. Check that the flue is in perfect condition (airtight, insulated, dry, etc.)
The fire flames up too much	Excessive primary air		Close the primary- and secondary-air intakes partially or totally
	Excessive updraught		Install a draught damper
Smoke given off on lighting	Poor-quality wood		Do not continually burn chips, carpentry scraps (plywood, pallets, etc.)
	Cold flue		Heat up the flue by burning a piece of paper in the firebox.
Smoke during burning	The room is at low pressure		In rooms with Controlled Mechanical Ventilation, leave an outdoor window ajar until the fire is fully alight.
	Too little wood loaded		Load as recommended. Loads notably smaller than those recommended lead to low smoke temperature and downdraught.
	Insufficient updraught		Check the condition of the flue and insulation. Check that the piping is not blocked. Clean mechanically if necessary
	Wind enters the flue		Install an anti-downdraught system (Cowl) at the top of the chimney
Does not warm up enough	The room is at low pressure		In rooms with Controlled Mechanical Ventilation, there must be an outdoor-air inlet
	Poor-quality wood		Only use the recommended fuel
The fans do not work	Electrical fault		
Water condenses (after the appliance has been lit more than 3 or 4 times)	Too little wood loaded		Load as recommended. Loads notably smaller than those recommended lead to low smoke temperature and condensation.
	Green or damp wood		Use hard woods, cut at least 2 years ago and stored in a sheltered, ventilated place.
	Condition of the flue		Lengthen the flue (5-6 metres minimum). Insulate the flue properly. Check the airtightness of the flue/appliance.

6. BASIC BREAKDOWNS
NIVE 800:


NIVE 1000:



No.	CODE	DESCRIPTION	QTY.
1	5045200001	Nive Adour 800 Frame	1
	5046200000	Nive Adour 1000 Frame	1
2	5047400000	Nive 800 Glass door with seal	1
	5047500000	Nive 1000 Glass door with seal	1
3	509020000042	Black cord Ø13mm (NIVE 800)	2.5 m
	5020000942	Black cord Ø15mm (NIVE 1000)	3 m
4	5047300001	Nive Right Vermiculite Side Panel	1
5	5047300002	Nive Left Vermiculite Side Panel	1
6	5047400001	Nive 800-1000 Right Vermiculite Base	1
7	5047400002	Nive 800-1000 Left Vermiculite Base	1
8	5047400003	Nive 800-1000 Right Vermiculite Rear Panel	1
9	5047400004	Nive 800-1000 Left Vermiculite Rear Panel	1
10	5047400006	Nive 800 Right Vermiculite Deflector	1
	5047400005	Nive 800 Left Vermiculite Deflector	1
	5047500001	Nive 1000 Right Vermiculite Deflector	1
	5047500002	Nive 1000 Left Vermiculite Deflector	1
11	5045200004	Adour/Nive 800 Upper Deflector	1
	5046200006	Adour/Nive 1000 Upper Deflector	1
12	5047300010	Nive Turbine (NIVE 800)	1
		Nive Turbine (NIVE 1000)	3
13	5040000912	Cast Nozzle Air Inlet/Outlet D/80 (Nive 800)	3
		Cast Nozzle Air Inlet/Outlet D/80 (Nive 1000)	5
14	5040000913	Adour Nive Smoke Outlet Ø150	1
15	5040000914	Adour Nive Common Draft Handle	1
16	5047300012	Nive Door Handle (without knob)	1
	5047500003	Nive 1000 Door Handle (without knob)	1
17	5040000928	ELX AIR SC21 Potentiometer	1
18	5021200008	Black Knob	1
19	5000000946	Nive 800 Deflector Reinforcement	1
	5000000948	Nive 1000 Deflector Reinforcement	1
22	5047500005	Nive 1000 Central Vermiculite Base	1
23	5047500006	Nive 1000 Central Vermiculite Rear Panel	1

7. PRODUCT RECYCLING

The recycling of the appliance is the exclusive responsibility of the owner, who must act in compliance with the laws in force in his country regarding safety, respect and protection of the environment. At the end of its useful life, the product must not be disposed of with urban waste.

It can be delivered to the specific selective collection centers set up by the municipalities, or to retailers who offer this service. The selective disposal of the product avoids possible negative consequences for the environment and for health and makes it possible to recover the materials of which it is composed, thus obtaining significant savings in terms of energy and resources.

It can be disassembled (the parts are assembled with screws or rivets) and the components can be deposited in their corresponding recycling channels. The components of the appliance are: steel, cast iron, glass, insulating materials, electrical material, etc.

8. CERTIFICATE OF COMPLIANCE

Certificate of Compliance

for

SOLID FUEL HEATERS

This is to certify that the appliance stated on this certificate has been tested for Thermal Clearances, Heat Output, Thermal Efficiency and Particulate Emissions in accordance with the Australian / New Zealand Standard(s) detailed below

<i>Manufacturer</i>	Lacunza
<i>Make</i>	Lacunza
<i>Model</i>	Nive 800
<i>Type</i>	Free-Standing/Inbuilt
<i>Category</i>	Slow combustion Wood Heater
<i>Fuel Type</i>	Hardwood
<i>Test Report No's:</i>	ASFT25106-1 ASFT26005-1, ASFT26012-1
<i>Maximum Avg Heat Output</i>	5.6kW
<i>Overall Avg Efficiency</i>	65%
<i>Particulate Emissions Factor</i>	0.9g/kg
<i>National Standards</i>	AS/NZS 4012 (2025) AS/NZS 4013 (2025) AS/NZS 2918 (2026)

ASFT hereby grants to:

Lacunza

of

31800 Alsasua / Navarra SPAIN

Certificate No.: **ASFT26C028**
Issue Date: **26 March 2026**

Certified Date: **27 March 2026**
Expiry Date: **20 June 2035**

Steve Marland

Managing Director of ASFT

ASFT performs compliance testing of Solid Fuel Appliances to the relevant Australian/New Zealand standards. This certification is subject to the conditions set forth in the characteristics above and is not to be construed as any recommendation, assurance or guarantee by ASFT of the product acceptance by Authorities having jurisdiction.



Certificate of Compliance

for

SOLID FUEL HEATERS

This is to certify that the appliance stated on this certificate has been tested for Thermal Clearances, Heat Output, Thermal Efficiency and Particulate Emissions in accordance with the Australian / New Zealand Standard(s) detailed below

<i>Manufacturer</i>	Lacunza
<i>Make</i>	Lacunza
<i>Model</i>	Nive 1000
<i>Type</i>	Free-Standing/Inbuilt
<i>Category</i>	Slow combustion Wood Heater
<i>Fuel Type</i>	Hardwood
<i>Test Report No's:</i>	ASFT25081-2 ASFT26013-1, ASFT26015-1
<i>Maximum Avg Heat Output</i>	9.2kW
<i>Overall Avg Efficiency</i>	67%
<i>Particulate Emissions Factor</i>	1.0g/kg
<i>National Standards</i>	AS/NZS 4012 (2025) AS/NZS 4013 (2025) AS/NZS 2918 (2026)

ASFT hereby grants to:

Lacunza

of

31800 Alsasua / Navarra SPAIN

Certificate No.: **ASFT26C029**
Issue Date: **26 March 2026**

Certified Date: **27 March 2026**
Expiry Date: **20 June 2035**

Steve Marland

Managing Director of ASFT

ASFT performs compliance testing of Solid Fuel Appliances to the relevant Australian/New Zealand standards. This certification is subject to the conditions set forth in the characteristics above and is not to be construed as any recommendation, assurance or guarantee by ASFT of the product acceptance by Authorities having jurisdiction.

LACUNZA KALOR GROUP S.A.L

Pol. Ind. Ibarrea 5A

31800 Alsasua (Navarra) Spain

Tel.: (00 34) 948 56 35 11

Fax.: (00 34) 948 56 35 05

e-mail: comercial@lacunza.net

Website: www.lacunza.net

EDITION: 03

