

SILVER PLUS

Instruction Book

AUSTRALIA

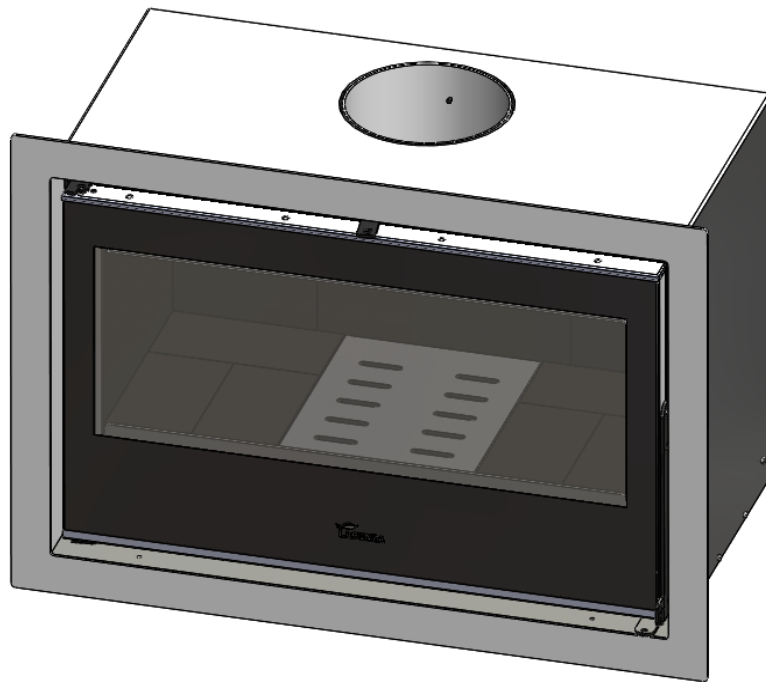

Lacunza congratulates you on your choice.
Certified under ISO 9001, Lacunza guarantees the quality of its appliances and undertakes to meet the needs of its customers.

Confident of the know-how afforded by more than 50 years' experience, Lacunza uses advanced technologies in the design and manufacture of its entire range of appliances. This document will help you install and use your appliance in optimum conditions for your comfort and safety.

CONTENTS

1. PRESENTATION OF THE APPLIANCE	3
1.1. General characteristics.....	3
2. INSTRUCTIONS FOR THE INSTALLER.....	11
2.1. Warning to installers.....	11
2.2. Room for installation.....	11
2.2.1. Location of the appliance in the room.....	11
2.3. Installation of the appliance.....	11
2.3.1. Safety distances for freestanding	11
2.3.2. Elevation clearance	13
2.3.3. Safety distances for in built.....	13
2.3.4. Checks before lighting for the first time.....	15
2.3.5. Height adjustment and levelling the appliance	15
2.3.6. Casing.....	15
2.3.7. Connection to the flue.....	17
2.3.8. Exterior Frame. Removal and assembly	17
2.4. Masonry section.....	17
2.5. Chimney flue.....	18
2.5.1. Type of flue.....	18
2.5.2. Chimney crown.....	19
3. INSTRUCTIONS OF USE	21
3.1. Fuel	21
3.2. Description of the parts of the appliance	22
3.2.1. Operating components	22
3.3. Lighting.....	23
3.4. Loading fuel	23
3.5. Operation	23
3.6. Removing ash	24
3.7. Deflectors.....	24
3.8. Electrical system (optional).....	25
4. MAINTENANCE AND IMPORTANT ADVICE.....	26
4.1. Maintenance of the appliance.....	26



4.1.1. Firebox	26
4.1.2. Inside the appliance	26
4.1.3. Flue socket	26
4.1.4. Firebox glass.....	26
4.1.5. Painted sheet-steel-cast-iron parts.....	26
4.1.6. Air intake registers	27
4.2. Maintenance of the chimney flue.....	27
4.3. Important advice.....	27
5. TROUBLESHOOTING.....	28
6. BASIC BREAKDOWNS	29
7. CERTIFICATE OF COMPLIANCE	31

1. PRESENTATION OF THE APPLIANCE

For optimum operation of the appliance, we advise you to read this manual carefully before switching on the appliance for the first time. In case of problems or concerns, we urge you to contact your dealer, who will cooperate with you.

In order to improve the product, the manufacturer reserves the right to make changes without notice by updating this document.

This appliance is designed to burn wood in absolutely safe conditions.

WARNING: Faulty installation may have serious consequences.

Installation and all necessary regular maintenance operations must be performed by an authorized installer in full accordance with the specifications set out in the legislation applicable in each country and this instruction book.

1.1. General characteristics

	Unit	Silver 800	Silver 1000	
MAXIMUM AVERAGE HEAT OUTPUT BURNING HARDWOOD	kW	6,7	7.9	
OVERALL AVERAGE EFFICIENCY BURNING HARDWOOD	%	70	65	
PARTICULATE EMISSIONS FACTOR	g/kg	0,9	0.7	
HIGH BURN	Average power (high primary air settings)	kW	6,7	7.9
	Average Peak Power	kW	10	11.3
	Efficiency (high primary air settings)	%	66	60
	Average dry fuel consumption rate (high primary air settings)	Kg/hr	1,9	1.6
	Particulate emission factor oven dry wood (high primary air settings)	g/kg	0,7	0.3
MEDIUM BURN	Average power (medium primary air settings)	kW	4,7	6.3
	Efficiency (medium primary air settings)	%	68	68
	Average dry fuel consumption rate (medium primary air settings)	Kg/hr	1,3	1.6
	Particulate emission factor oven dry wood (medium primary air settings)	g/kg	0,7	0.8
LOW BURN	Average power (low primary air settings)	kW	3,7	4.4
	Efficiency (low primary air settings)	%	75	68
	Average dry fuel consumption rate (low primary air settings)	Kg/hr	0,9	1.1
	Particulate emission factor oven dry wood (low primary air settings)	g/kg	1,4	456
Dimensions of the firebox				
Width	mm	695	890	
Depth	mm	335	335	
Useful height	mm	170-240	174-245	
Length of the logs	cm	24	36	
Capacity of the ashpit	L	1,5	1.5	
Weight	kg	107	132	
Flue socket diameter	mm	200	200	

WARNINGS

KEEP THESE INSTRUCTIONS FOR FUTURE REFERENCE!

WARNING: THE APPLIANCE AND FLUE SYSTEM SHOULD BE INSTALLED IN ACCORDANCE WITH AS/NZS 2918 AND THE APPROPRIATE REQUIREMENTS OF THE RELEVANT BUILDING CODE OR CODES.

WARNING: APPLIANCES INSTALLED IN ACCORDANCE WITH AS/NZS 2918 SHOULD CONFORM TO THE REQUIREMENTS OF AS/NZS 4013 AND AS/NZS 4012 WHERE REQUIRED BY THE REGULATORY AUTHORITY. THE APPLIANCE SHOULD BE IDENTIFIABLE BY A CONFORMANCE PLATE MARKED 'TESTED TO AS/NZS 4013 AND AS/NZS 4012' AS SPECIFIED IN AS/NZS 4012 ANY MODIFICATION OF THE APPLIANCE THAT HAS NOT BEEN APPROVED IN WRITING BY THE TESTING AUTHORITY IS CONSIDERED TO BE IN BREACH OF THE APPROVAL GRANTED FOR CONFORMANCE TO AS/NZS 4013.

WARNING: ANY MODIFICATION OF THE APPLIANCE THAT HAS NOT BEEN APPROVED IN WRITING BY THE TESTING AUTHORITY IS CONSIDERED NOT CONFORMING TO AS/NZS 4013.

WARNING: DO NOT USE FLAMMABLE LIQUIDS OR AEROSOLS TO START OR REKINDLE THE FIRE.

WARNING: DO NOT USE FLAMMABLE LIQUIDS OR AEROSOLS IN THE VICINITY OF THIS APPLIANCE WHEN IT IS OPERATING.

WARNING: DO NOT STORE FUEL WITHIN HEATER INSTALLATION CLEARANCES.

WARNING: WHEN OPERATING THIS APPLIANCE AS AN OPEN FIRE, USE A FIRE SCREEN.

WARNING: OPEN THE AIR CONTROL (AND DAMPER WHEN FITTED) BEFORE OPENING THE FIRING DOOR

WARNING: DO NOT BURN WOOD THAT IS PAINTED, COATED WITH PLASTIC, OR HAS BEEN TREATED WITH ANY CHEMICAL.

CAUTIONS

CAUTION: MIXING APPLIANCE OR FLUE SYSTEM COMPONENTS FROM DIFFERENT SOURCES OR MODIFYING THE DIMENSIONAL SPECIFICATION OF COMPONENTS MAY RESULT IN HAZARDOUS CONDITIONS. WHERE SUCH ACTION IS CONSIDERED, THE MANUFACTURER SHOULD BE CONSULTED IN THE FIRST INSTANCE.

CAUTION: CRACKED AND BROKEN COMPONENTS, FOR EXAMPLE, GLASS PANELS OR CERAMIC TILES, MAY RENDER THE INSTALLATION UNSAFE

CAUTION: DO NOT OPERATE THIS APPLIANCE IF GLASS IS CRACKED OR BROKEN.

CAUTION: THIS APPLIANCE SHOULD BE MAINTAINED AND OPERATED AT ALL TIMES IN ACCORDANCE WITH THESE INSTRUCTIONS.

Warning: this appliance is designed and prepared to work with the types of fuel, degree of humidity of the fuel, fuel loads, fuel load frequencies, flue draught and system of installation indicated in this Instruction Book. Failure to respect these conditions may lead to problems with the appliance (deterioration, shorter useful life, etc.) which are not covered by the Lacunza warranty.

To obtain these data, tests have been done on the standards AS/NZS 4012 (2014), AS/NZS 4013 (2014) and AS/NZS 2918 (2018), with eucalyptus wood.

IN BUILT

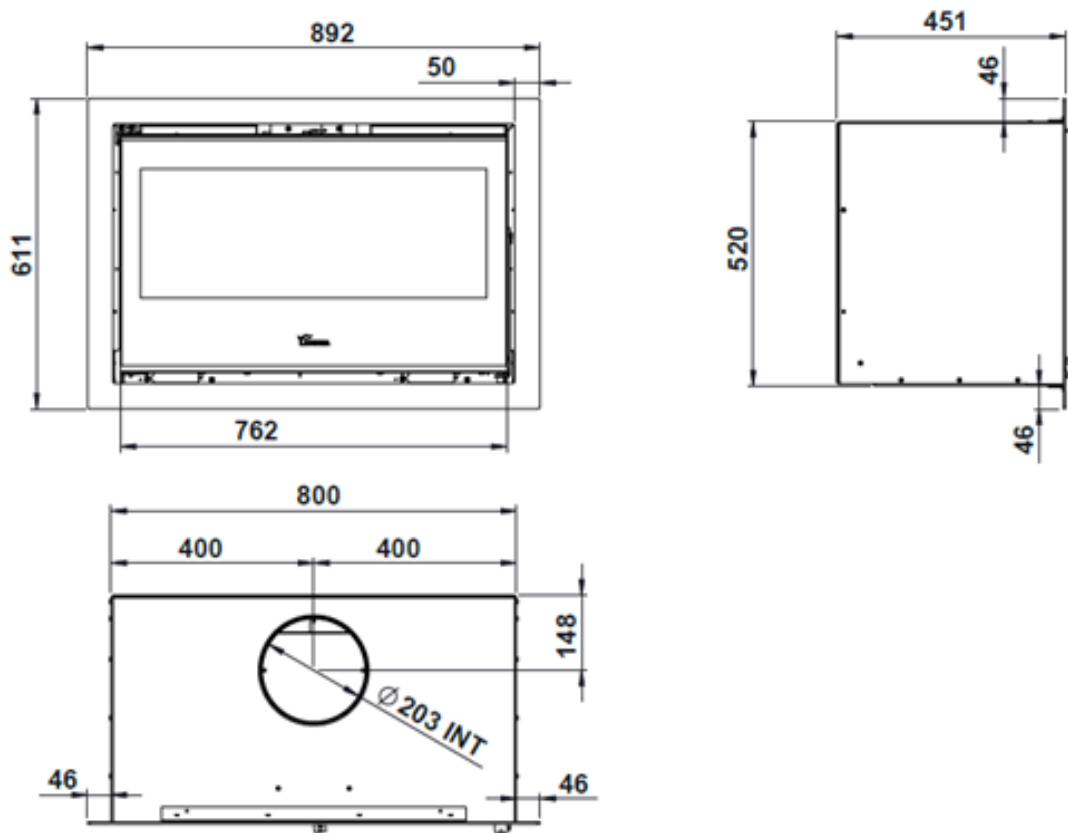

Figure No.1 - Dimensions of the SILVER 800 PLUS In Built appliance in mm

IN BUILT

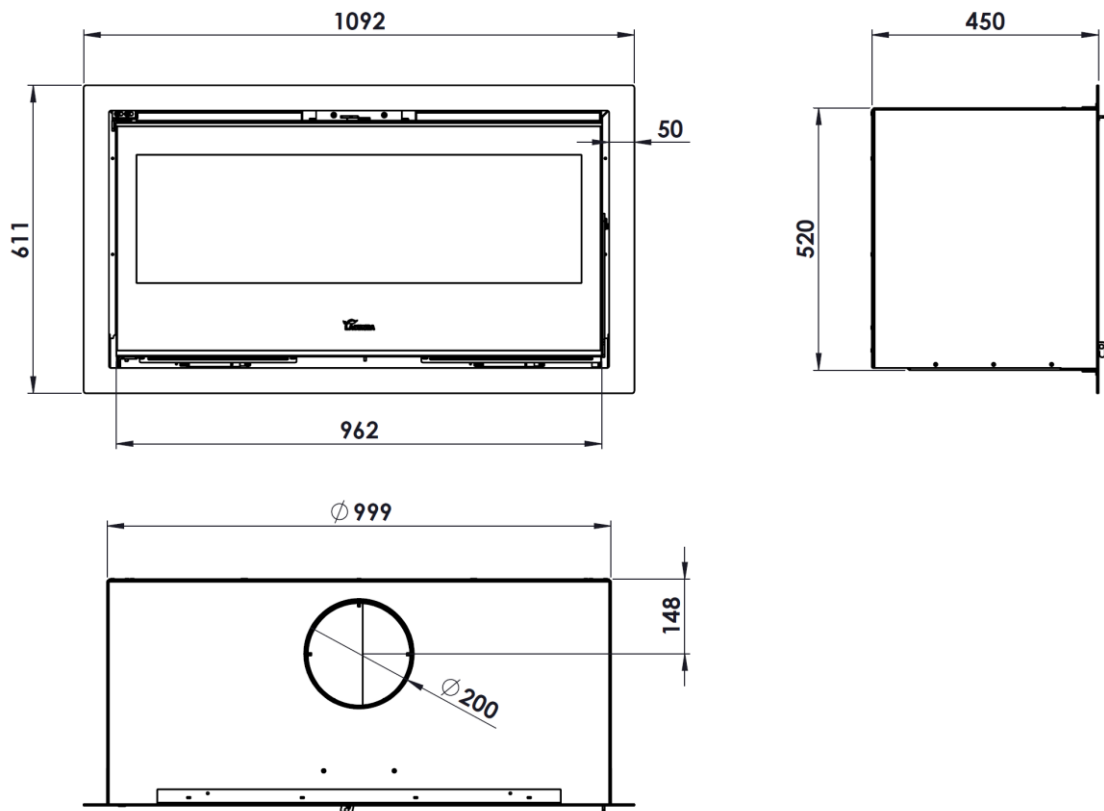

Figure No.2 - Dimensions of the SILVER 1000 Plus In Built appliance in mm

FREESTANDING

Figure No.3 - Dimensions of the SILVER 800 PLUS Freestanding appliance in mm

FREESTANDING

Figure No.4 - Dimensions of the SILVER 1000 PLUS Freestanding appliance in mm

FREESTANDING WITH WOODBOX

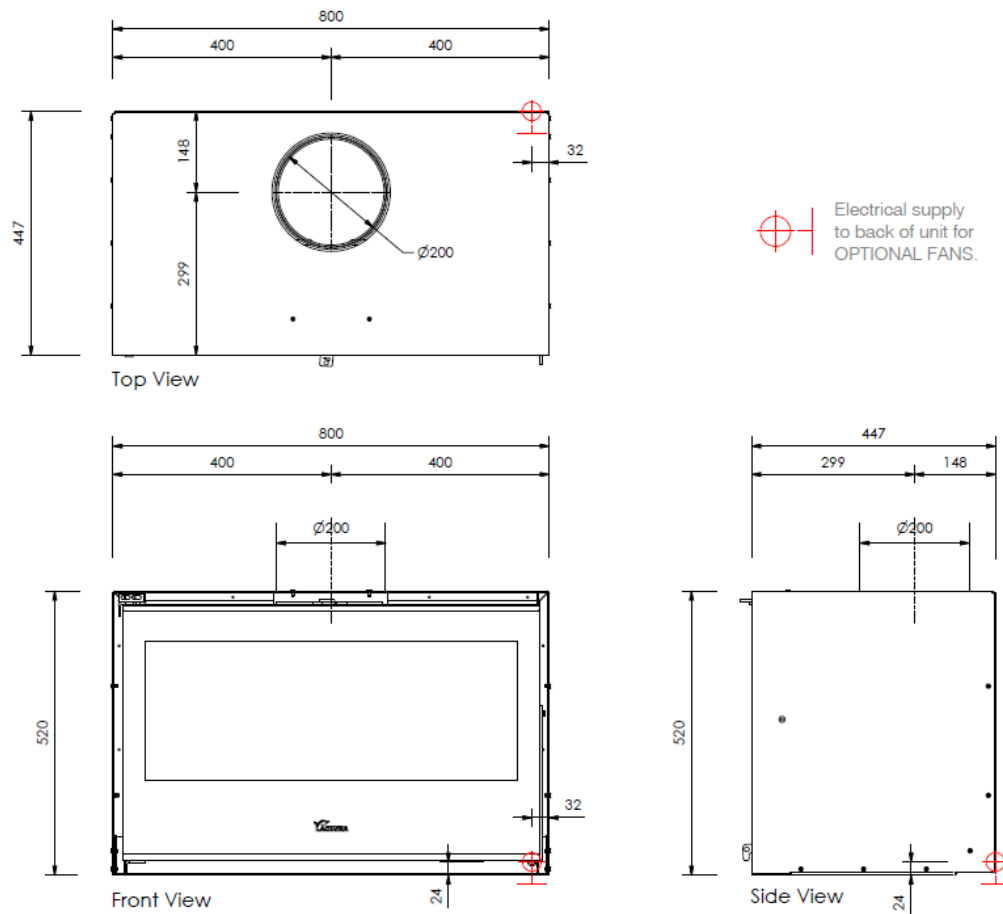
Figure No.5 - Dimensions of the SILVER 800 PLUS Freestanding with woodbox appliance in mm

FREESTANDING WITH WOODBOX

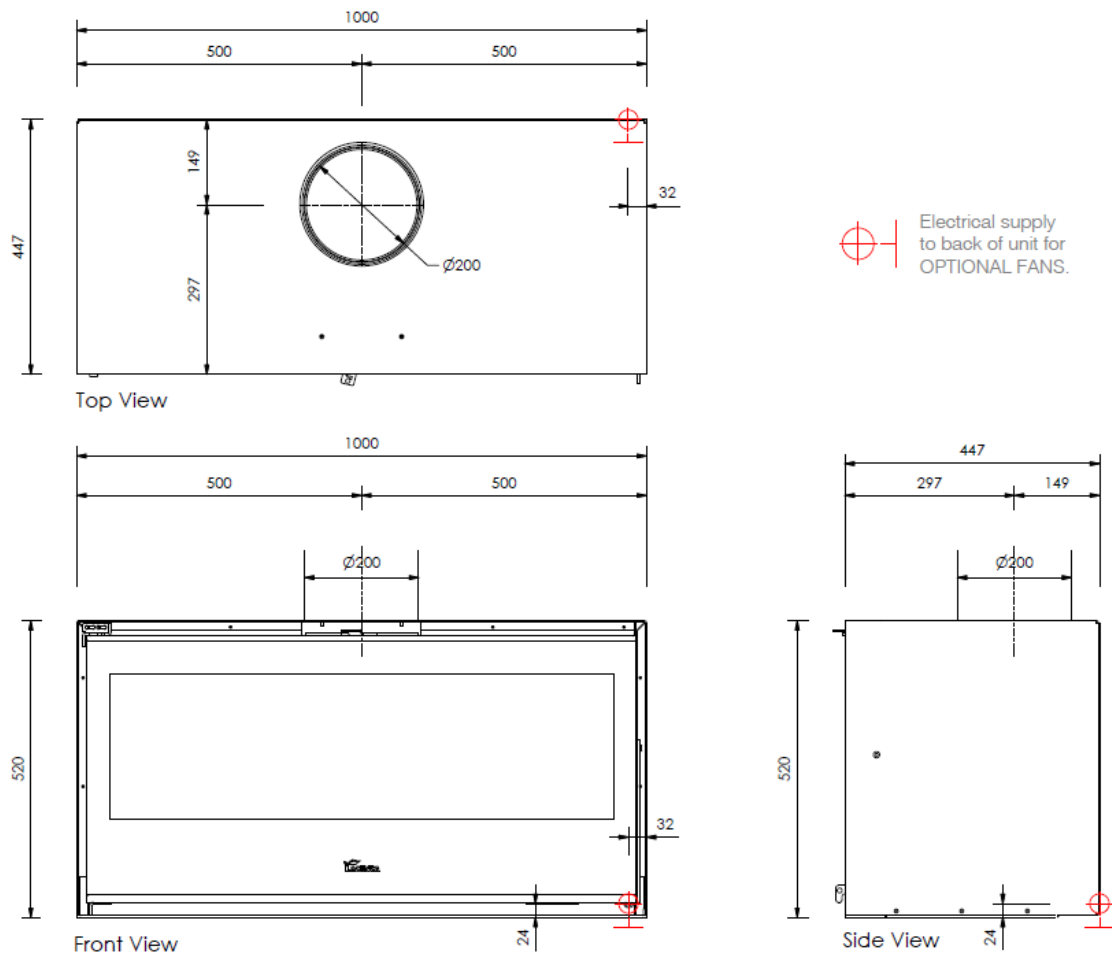
Figure No.6 - Dimensions of the SILVER 1000 PLUS Freestanding with woodbox appliance in mm

2. INSTRUCTIONS FOR THE INSTALLER

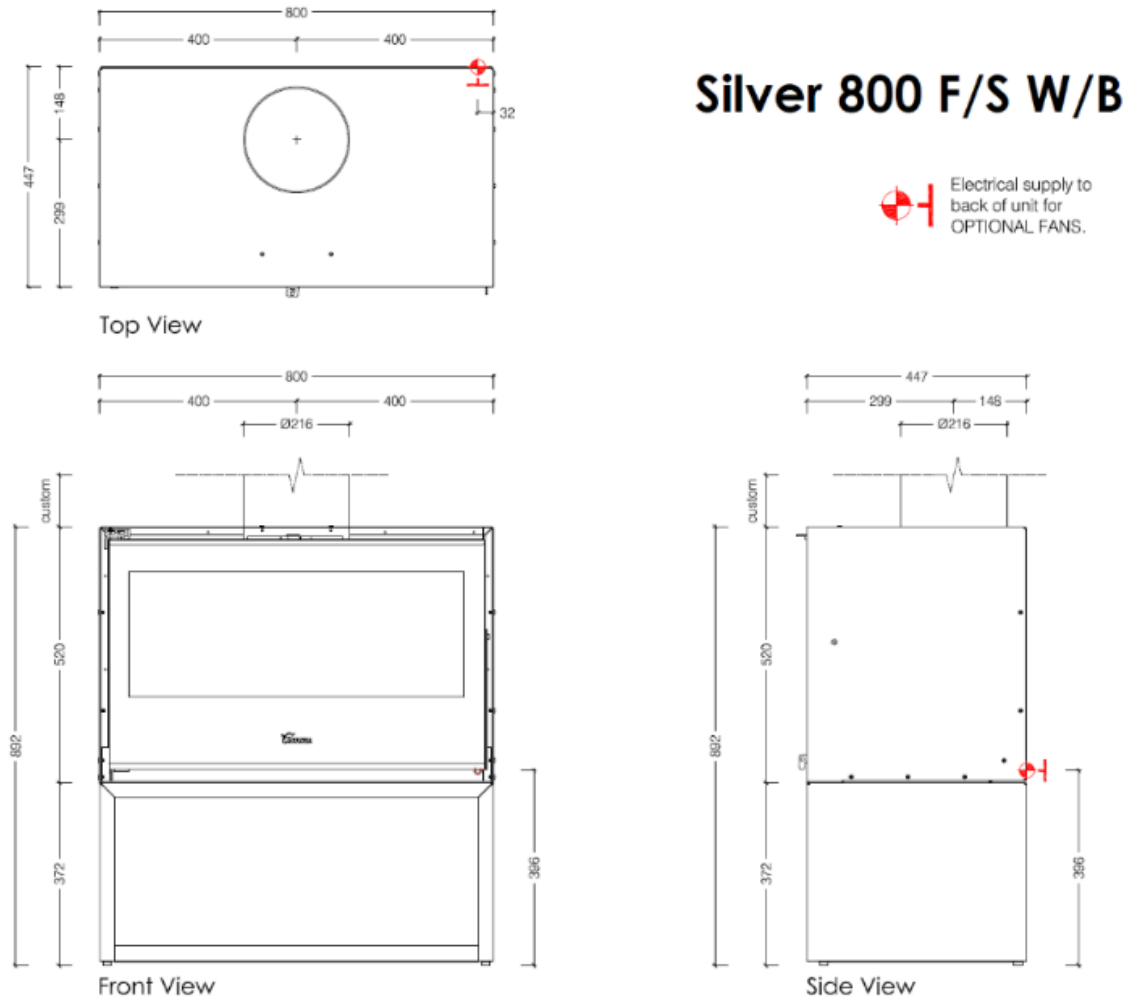
2.1. Warning to installers

All local and national regulations, including all those referring to national and European standards, must be observed when installing the appliance.

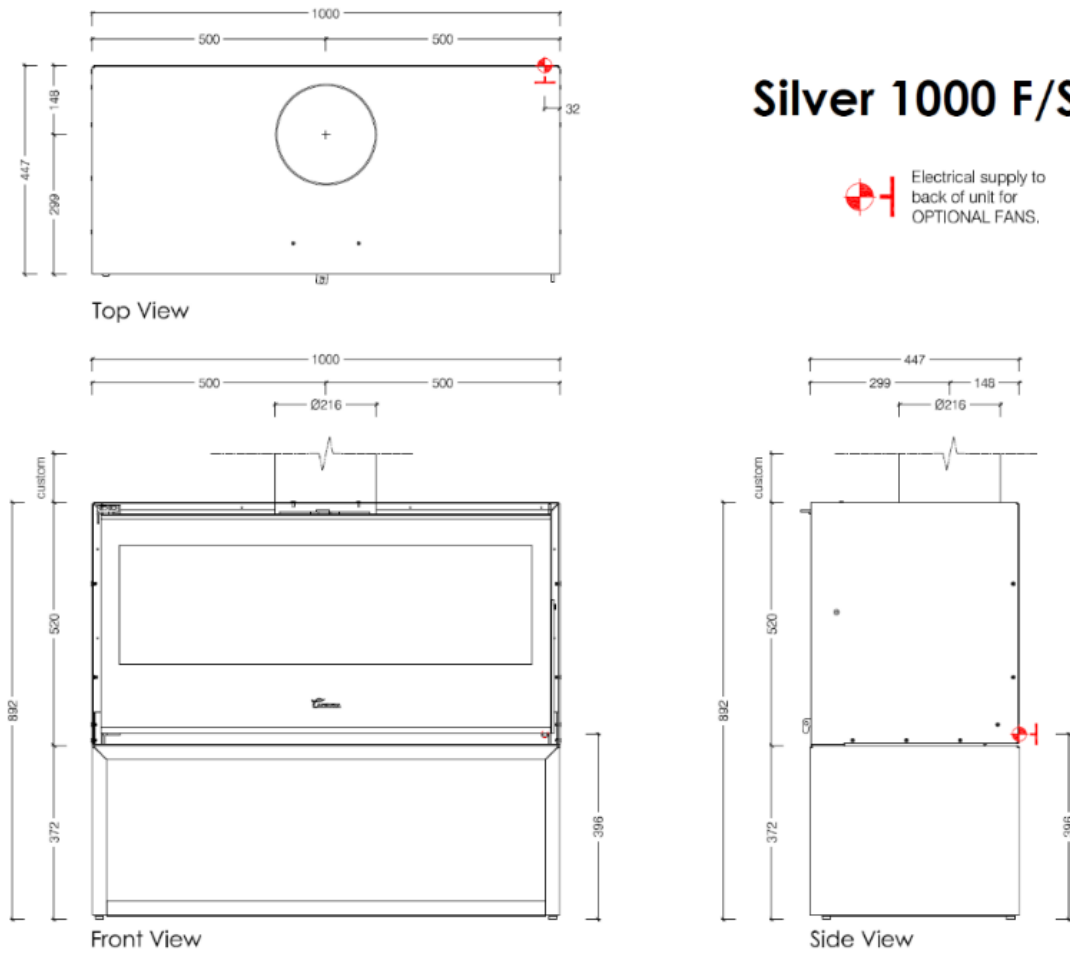
Installation of the appliance must be performed by an authorised installer.

An incorrectly installed appliance may lead to serious incidents (fires, creation of harmful gases, deterioration of nearby fixtures, etc.).

Lacunza's liability is limited to the supply of the material and does not include installation of the appliance.

2.2. Room for installation

This appliance must be installed in compliance with AS/NZS 2918 (or latest version) and all applicable building regulations. Ensure provision of adequate ventilation or external air supply to the room in which the appliance is installed. Insufficient air supply or blockage of the flue may result in inefficient combustion, smoke in the room, elevated emissions and unsafe operation. Use only dry, seasoned wood, and operate the air controls as instructed. Regularly inspect and clean the flue system. Installation and servicing must be carried out by a qualified installer.

2.2.1. Location of the appliance in the room

Choose a location in the room which favours good hot-air distribution by convection and radiation.

2.3. Installation of the appliance

Make sure that the base can withstand the total constructed weight of the appliance and its casing.

When the floor surface (base) is combustible, fit suitable insulation.

2.3.1. Safety distances for freestanding

Be sure to respect the appliance installation distances from **combustible materials**.

Silver 1000 Plus

A minimum 1000mm deep x 1285mm wide x 50mm thick floor protector (Skamol board) should be used under the appliance base when installing the appliance (see joint AS/NZS 2918:2018 3.3.2). A minimum 550mm deep x 1285mm wide x 36mm thick floor protector (compressed board) should be used in front of the appliance door and be placed centrally in the 1285mm width. The Thermal resistivity of the 50mm skamol board floor protector is $0.74\text{m}^2.\text{K}/\text{W}$. The Thermal resistivity of the floor protector is $0.16\text{m}^2.\text{K}/\text{W}$ for 36mm thick compressed board sheets.

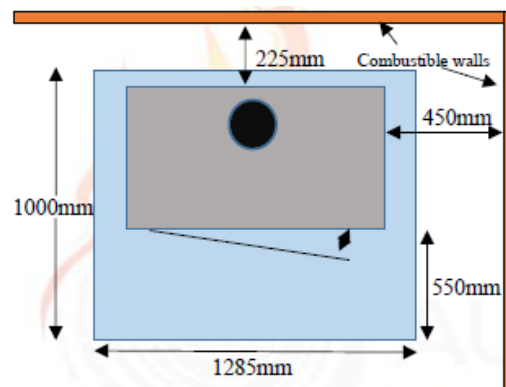

Figure No.7 - Safety distances of Silver 1000 Plus in parallel position

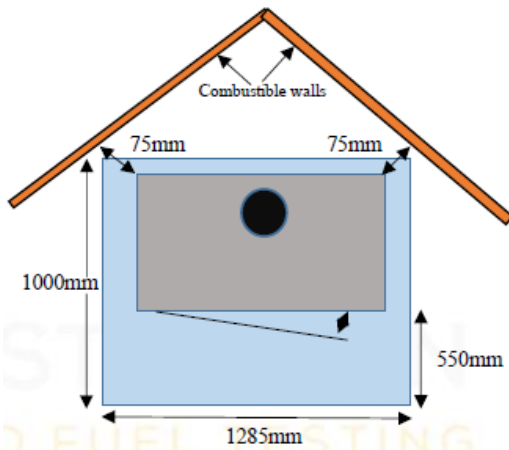

Figure No.8 - Safety distances of Silver 1000 Plus in corner position

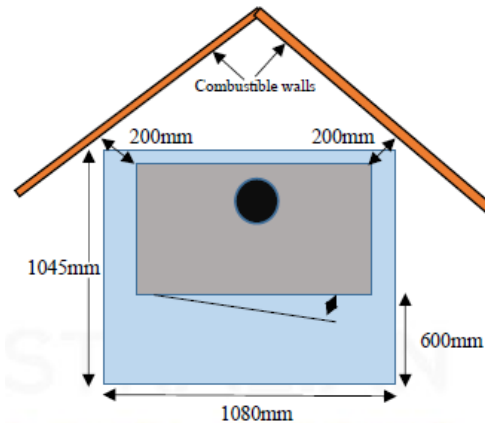

Figure No.10 - Safety distances of Silver 800 Plus in corner position

Silver 800 Plus

A minimum 1045mm deep x 1080mm wide x 50mm thick floor protector (Skamol board) should be used under the appliance base when installing the appliance (see joint AS/NZS 2918:2018 3.3.2). A minimum 600mm deep x 1080mm wide x 50mm thick floor protector (Skamol board) should be used in front of the appliance door and be placed centrally in the 1080mm width. The Thermal resistivity of the 50mm skamol board floor protector is $0.74\text{m}^2.\text{K}/\text{W}$.

Silver 800 Plus with additional rear heatshield

A minimum 1060mm deep x 1080mm wide x 50mm thick floor protector (Skamol board) should be used under and in front of the appliance base when installing the appliance (see joint AS/NZS 2918:2018 3.3.2). The floor protector should extend 600mm in front of the appliance door and be placed centrally in the 1080mm width. The Thermal resistivity of the 50mm skamol board floor protector is $0.74\text{m}^2.\text{K}/\text{W}$.

For this option you have to place the rear heatshield following this steps:

- Fit the shield to the width of the rear part matching it to the lower part.

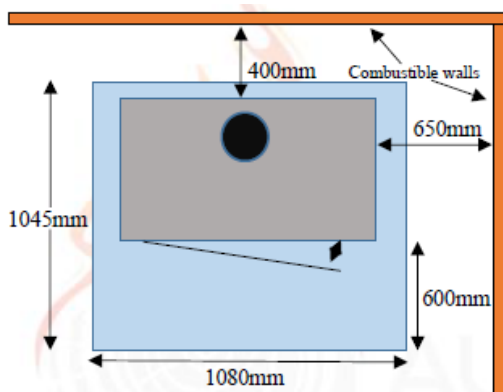

Figure No.9 - Safety distances of Silver 800 Plus in parallel position

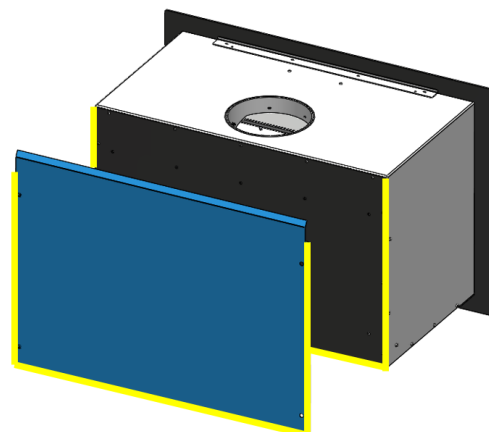

Figure No.11 - How to place the rear heatshield

- Drill the four holes (Ø3.5mm).
- Screw on the shield with four Torx M4x10 DIN 7985 screws.

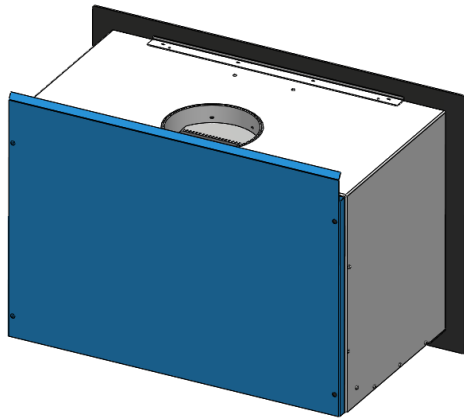

Figure No.12 - Rear heatshield placed

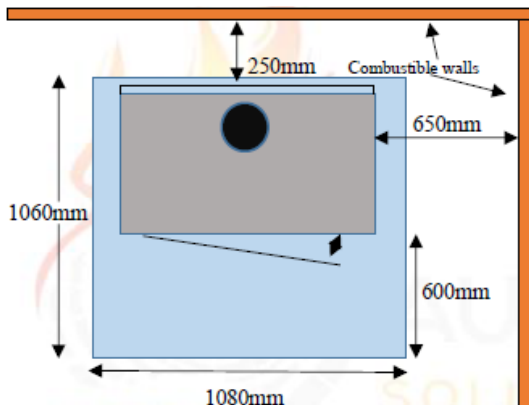
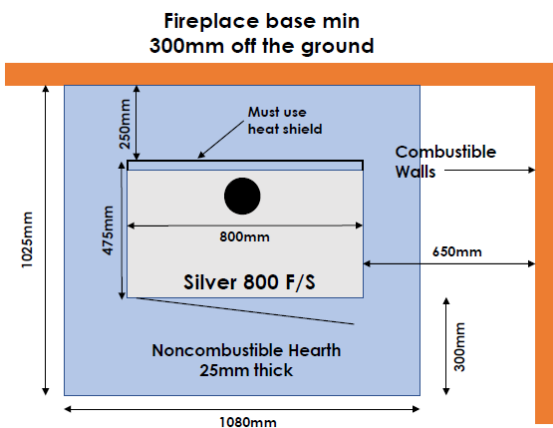
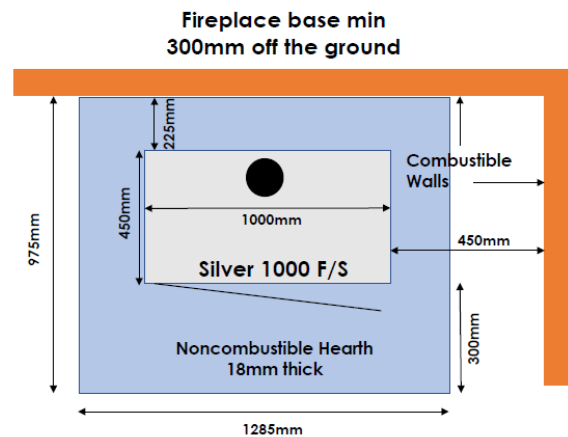

Figure No.13 - Safety distances in corner position of Silver 800 Plus with additional rear heatshield

2.3.2. Elevation clearance



Silver 800 Hearth Size	Front in m	Thickness in mm
Flat on ground	0.6	50
Raised 100 mm	0.496	50
Raised 200 mm	0.3347	25
Raised 300 mm	0.3	25
Raised 400 mm	0.3	25
Raised 500 mm	0.3	25



Silver 1000 Hearth Size	Front in m	Thickness in mm
Flat on ground	0.55	36
Raised 100 mm	0.422	36
Raised 200 mm	0.3	18
Raised 300 mm	0.3	18
Raised 400 mm	0.3	18
Raised 500 mm	0.3	18

2.3.3. Safety distances for in built

Be sure to respect the appliance installation distances from **combustible materials**.

Silver 800 Plus inbuild and zero clearance box

A minimum 600mm deep x 1270mm wide x 6mm thick floor protector (compressed board) should be used under the appliance base when installing the appliance (see joint AS/NZS 2918:2018 3.3.2). A minimum 1080 x 550mm x 6mm thick floor protector (compressed board) should be used in front of the enclosure base. The floor protector should extend 550mm in front of the appliance door and be placed centrally in the 1080mm width. The Thermal resistivity of the floor protector is 0.026m².K/W for 6mm thick compressed cement sheets. The appliance was installed 500mm above the floor protector.

The hot air outlet vent must be below the heat deflector to stop heat build-up in the enclosure.

Cooling air should be able to pass into the bottom air vent and circulate around the clearance box and exit through the hot air outlet.

There should be clearance around the flue exiting through the ceiling (about 100mm).

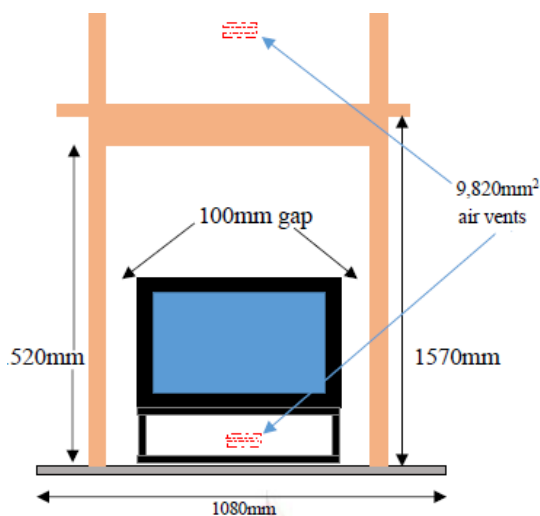

Figure No.14 - Front view of safety distances of Silver 800 Plus inbuild and zero clearance box

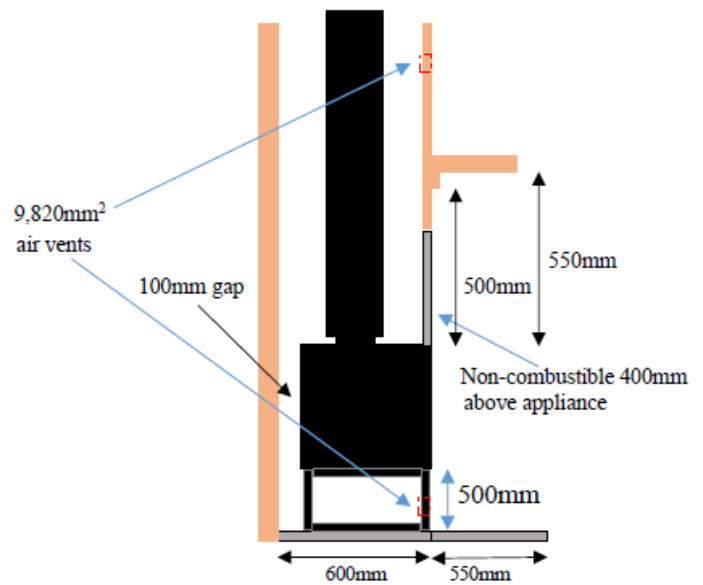

Figure No.15 - Profile view of safety distances of Silver 800 Plus inbuild and zero clearance box

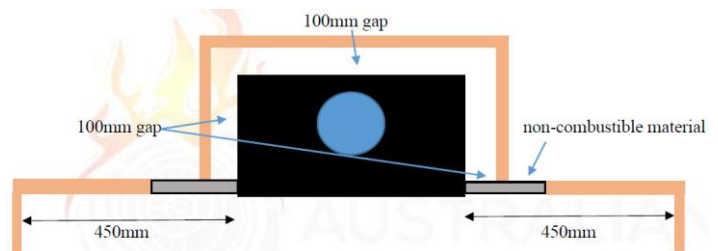

Figure No.16 - Floor view of safety distances of Silver 800 Plus inbuild and zero clearance box

Silver 1000 Plus inbuild and zero clearance box

A minimum 600mm deep x 1270mm wide x 6mm thick floor protector (compressed board) should be used under the appliance base when installing the appliance (see joint AS/NZS 2918:2018 3.3.2). A minimum 1285 x 550mm x 6mm thick floor protector (compressed board) should be used in front of the enclosure base. The floor protector should extend 550mm in front of the appliance door and be placed centrally in the 1285mm width. The Thermal resistivity of the floor protector is 0.026m².K/W for 6mm thick

compressed cement sheets. The appliance was installed 500mm above the floor protector.

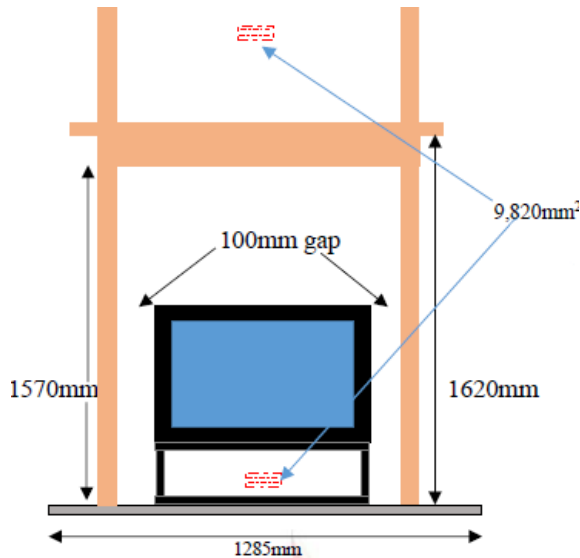

Figure No.17 - Front view of safety distances of Silver 1000 Plus inbuilt and zero clearance box

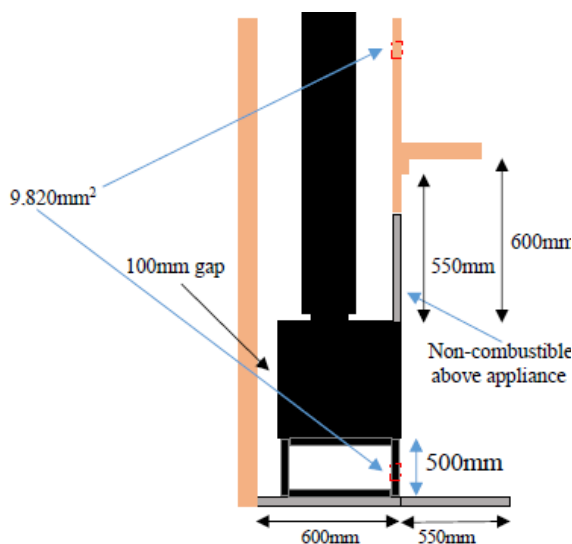

Figure No.18 - Profile view of safety distances of Silver 1000 Plus inbuilt and zero clearance box

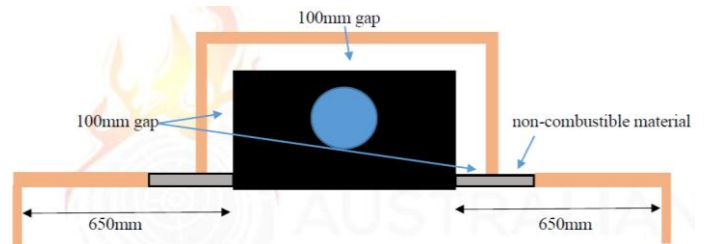

Figure No.19 - Floor view of safety distances of Silver 1000 Plus inbuilt and zero clearance box

Bear in mind that it may even be necessary to protect non-combustible material in order to prevent breakage, deformation, etc., as a result of overheating if the non-combustible material is not designed to withstand high temperatures.

2.3.4. Checks before lighting for the first time

- Make sure that the glass is not broken or damaged.
- Make sure that the flueway is not obstructed with packing or loose parts.
- Make sure that the airtight joints on the flue circuit are in perfect condition.
- Make sure that the doors close properly.
- Make sure that all moving parts are fitted in place.
- Check that the deflector is fitted properly

2.3.5. Height adjustment and levelling the appliance

The appliance must be perfectly level, horizontally and vertically, both at the front and on the sides (use a spirit level).

2.3.6. Casing

If the customer would like to coat the appliance, the following instructions should be followed.

Make sure that the material around the appliance is not flammable or likely to

deteriorate as a result of heat (wallpaper, carpet, plastic-based casing, Silestone, etc.).

The image below gives an example of how the appliance can be encased properly:

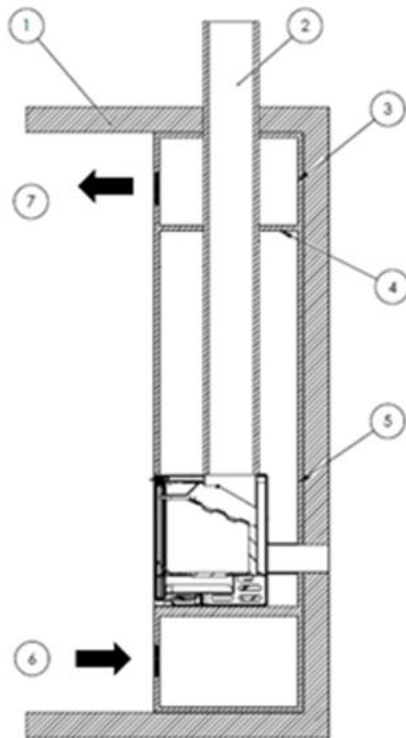

Figure No.20 - Interior diagram of the casing

Key to casing diagram:

- 1 Ceiling
- 2 Flue
- 3 Incombustible material (Inner hood insulation)
- 4 Insulating deflector made of incombustible material
- 5 Wall
- 6 Fresh-air inlet (9.820 cm²)
- 7 Hot-air outlet (9.820 cm²)



Figure No.21 - Exterior diagram of the casing

In order to enable suitable air circulation and correct operation, the casing must have a fresh-air inlet with a minimum section of 1,000cm² beneath the level of the actual appliance and a hot-air outlet measuring at least 1,000cm² above it (just before the insulating deflector inside the casing). These inlet and outlet sections must ensure air renewal in such a way as to avoid damage to parts inside the hood due to excess temperature.

This specification must be observed regardless of the type of installation chosen (with or without forced ventilation, combustion air from indoors or outdoors, directed hot-air outlets with or without pipes, etc.). A further hot-air ventilation grille is also recommended between the insulating deflector on the hood and the ceiling.

Warning: on appliances on which it is possible to pipe air to the firebox, the hood requires a further air inlet at the bottom, in addition to the 1,000cm² inlet, if the air supply comes from the room in which the appliance is fitted.

On non-central-heating appliances (without back boiler), Lacunza does not recommend enveloping the outside of appliances with insulation.

The installer must fit the necessary inspection accesses (trap doors, hatches, etc.) so that everything inside the hood that may need maintenance work or replacement can be accessed at any time.

2.3.7. Connection to the flue

The appliance must be connected to the chimney flue using special piping designed to resist the products of combustion (e.g. stainless steel, enamelled steel, etc.).

To connect the flue to the socket flange, insert the piping inside the flange and seal the joint with fire sealant or fire cement to make it completely airtight.

The installer must ensure that the pipe connected to the appliance is well secured and there is no chance of it coming free from its housing (e.g. as a result of dilatation due to temperature, etc.).

On this appliance, the flue socket can be fitted on top of the appliance.

2.3.8. Exterior Frame. Removal and assembly

To fit the frame, proceed as follows:

- Bend all the tabs located in the upper and lower part of the frame, as shown in the picture.

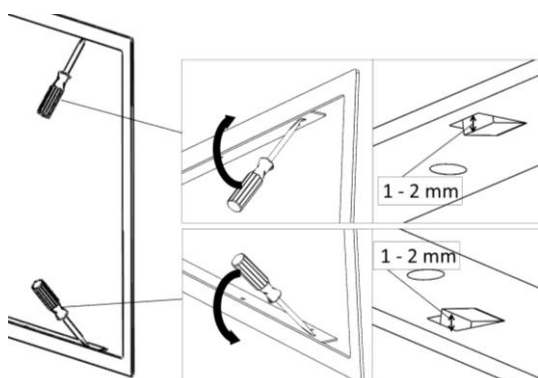

Figure No.22 - Bending the tabs

- Insert the frame in the appliance pressing.

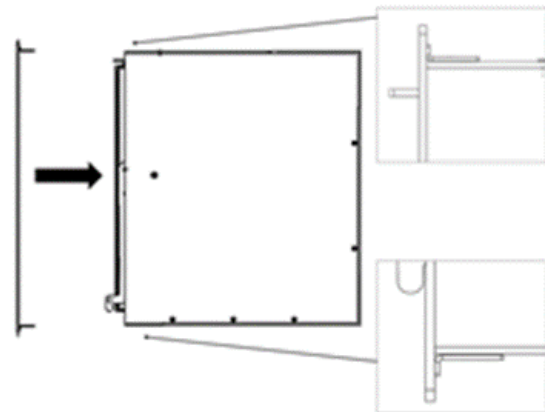

Figure No.1 - Insert frame in the appliance

- To remove the frame, perform the same operation in reverse order

2.4. Masonry section

The Unit when referring to installation into Masonry should allow 50mm air gap around the unit sides and rear to allow for Thermal expansion. It is recommended to vent where possible below and above the unit.

AS/NZS 2918:2018

Masonry: A bonded construction using clay bricks, concrete bricks or blocks, pumice concrete, sand-lime bricks, square-dressed natural stone, terracotta, or similar materials laid manually unit by unit and set in mortar.

Masonry chimney: A masonry structure, usually vertical, containing a passage or flue through which smoke, gases, and other products of combustion from a fire are carried to the outside of a building and by means of which a draught is created to assist combustion.

Masonry enclosure: An open-fronted masonry structure not incorporating an integral masonry chimney, originally designed to surround a solid-fueled cooking and/or heating appliance.

Masonry fireplace: A fireplace constructed from masonry materials.

Masonry recess: A construction of masonry materials designed for use as a surround or recess for the installation of a freestanding domestic solid fuel burning appliance.

Open-vented hot-water system: A hot-water system that has an unobstructed vent to the atmosphere, with the highest point of the vent no greater than 5 m above the lowest point of the system.

Penetrations

Flat ceiling penetration: Where the angle (slope) of the ceiling is 30° or less from the horizontal plane.

Sloped ceiling penetration

Where the angle (slope) of the ceiling is greater than 30° but less than 60° from the horizontal plane.

Wall penetration: Where the angle (slope) of the wall or ceiling is between 60° and 90° from the horizontal plane.

2.5. Chimney flue

The chimney flue must comply with present standards on the installation of chimneys.

In rooms equipped with Controlled Mechanical Ventilation, the ventilation outlet must never be connected to the flue.

The appliance must always have its own chimney flue, never sharing a chimney flue with another appliance.

2.5.1. Type of flue

SILVER 800-1000 FREE-STANDING

The flue system used during testing was a Flo-met Flue Kit incorporating a 515mm ceiling ring with a 15mm air gap between the ceiling and the ceiling ring, the 250mm solid flue casing above the

appliance must be modified to shield all of the appliance spigot. This flue system has not been tested to joint AS/NZS 2918:2018, Appendix F. The flue height was 4.6 ± 0.1 m from the floor protector.

SILVER 800-1000 INBUILT ZERO CLEARANCE BOX

The flue system used during testing was a Flo-met Flue Kit incorporating 250mm Inner galvanised casing vented into the zero clearance box outer skin and a 300mm outer casing raised 65mm above the zero clearance box. This flue system has not been tested to joint AS/NZS 2918:2018, Appendix F. The flue height was 4.6 ± 0.1 m from the floor protector.

The flue must be made of special material designed to resist the products of combustion (e.g. stainless steel, enamelled steel, etc.).

If the chimney is constructed, then it is necessary to pipe and insulate it to ensure correct updraught.

The diameter of the pipe must be the same as the diameter of the flue socket on the appliance over its entire length in order to ensure correct operation.

The flue must prevent the entry of rainwater.

The flue must be clean and airtight over its entire length.

It's highly recommended that the flue is a minimum of 5 meters high. Less than 5 meters could result in the fireplace not operating correctly. And the chimney cap must not hinder the free release of gases.

If the flue tends to suffer from downdraught, then it is necessary to fit an effective anti-downdraught cowl, a static cowl or a smoke extraction fan, or reshape the chimney.

Never make 90° bends, due to the great loss of draught they cause, and reduce 45° bends down to an absolute minimum. Each 45° bend is equivalent to a 0.5m

reduction in flue length. Horizontal flue sections should not be installed because they cut updraught a great deal.

The appliance is designed to operate under controlled draught conditions. The appliance must operate at a chimney draught of between 12Pa and 15Pa. To ensure this draught, an automatic draught moderator must be installed in the flue. Uncontrolled draught operation can lead to quick damage of the appliance, which will not be covered by the warranty.

The flue must not rest its weight on the appliance, as this could damage the worktop.

Bear in mind that high temperatures may be reached in the flue, meaning that it is essential that insulation be enhanced in sections in which combustible material is present (wooden beams, furniture, etc.). It may even be necessary to protect non-combustible material in order to prevent breakage, deformation, etc., as a result of overheating if the material is not designed to withstand high temperatures.

It must be possible to clean the entire flue, no sections being left inaccessible for cleaning purposes.

2.5.2. Chimney crown

Minimum bending length: Refer to the standard to be tested in accordance with appendix F of AS/NZS 2918.

The upper end of the chimney must clear the roof, the roof ridge or any obstacle located on the roof by at least 1m.

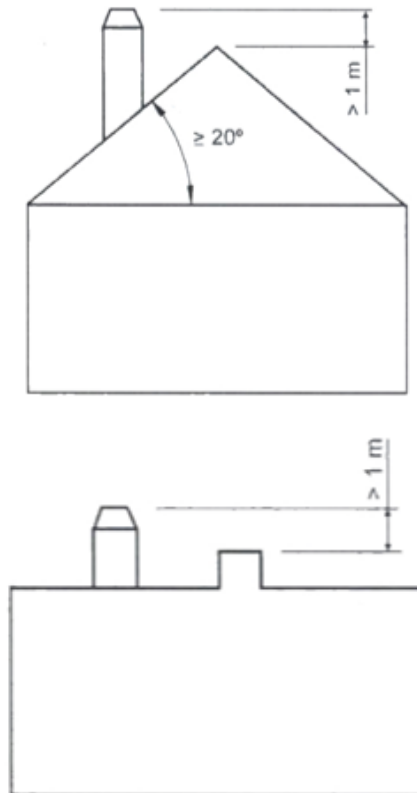
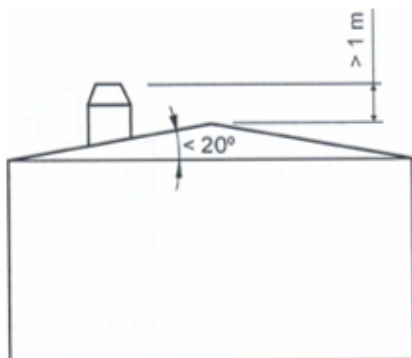

Figure No.2 - Distances between chimney crown and roof ridge

The chimney crown must clear the highest point of any neighbouring building or obstacle located within a 10m radius of the chimney outlet by more than 1m.

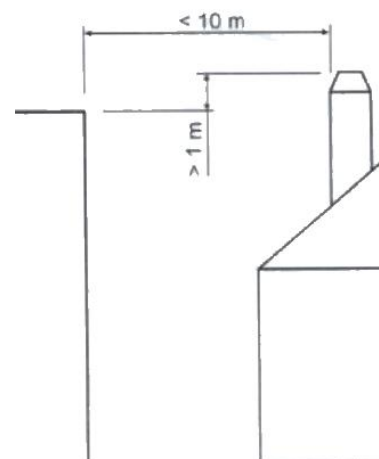

Figure No.3 - Distances between the chimney crown and objects within a 10m radius



The chimney crown must clear any neighbouring building or obstacle located within a radius of 10m to 20m from the chimney outlet.

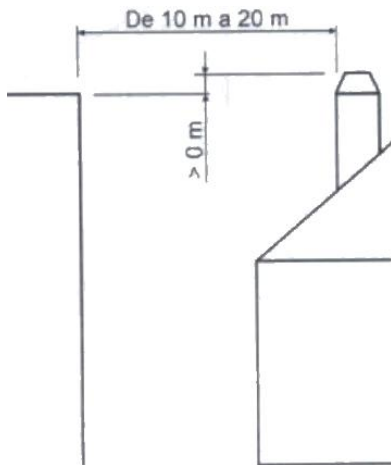

Figure No.4 - Distances between the chimney crown and objects within a radius of between 10 and 20m

3. INSTRUCTIONS OF USE

The manufacturer accepts no liability whatsoever for damage caused to parts as a result of the improper use of non-recommended fuels, modifications made to the appliance or how it is installed.
Only use original replacement parts.

All local and national regulations, including those referring to national and European standards, must be observed when using the appliance.

Heat is diffused by radiation and convection via the front and exterior of the appliance.

3.1. Fuel

This appliance must not be used as an incinerator. Do not use non-recommended fuels.

- Use dry logs (max. 16% humidity), cut at least 2 years ago, clean of resin and stored in a sheltered, ventilated place.
- Use hard woods with high calorie values and good ember production.
- Large logs should be cut to useable lengths before being stored. The logs should have a maximum diameter of 150mm.
- Finely-chopped wood produces greater heat output, but also burns more quickly.

Optimum fuels:

- Beech, hardwood and eucalyptus logs.

Other fuels:

- Oak, chestnut, ash, maple, birch, elm, etc.
- Resinous wood may mean that the appliance and the flue need to be cleaned more often.

Non-permitted fuels:

- All types of coal and liquid fuel.
- “Green wood”. Green or damp wood reduces the performance of the appliance and leads to soot and tar build-up on the inner walls of the flue, obstructing it.
- “Recovered wood”. The burning of treated woods (railway sleepers, telegraph posts, plywood, fibreboard, pallets, etc.) quickly blocks the system (soot and tar build-up), harms the environment (pollution, smells) and may lead to deformation of the firebox due to overheating.
- All materials which are not wood (plastic, spray cans, etc.).

Green and reprocessed wood may cause chimney fires.

The graph below shows how the humidity of firewood affects its heat output:

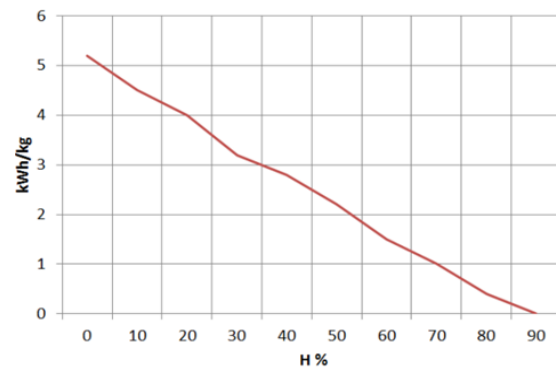

Figure No.5 - Relationship between firewood humidity and heat output.

3.2. Description of the parts of the appliance

3.2.1. Operating components

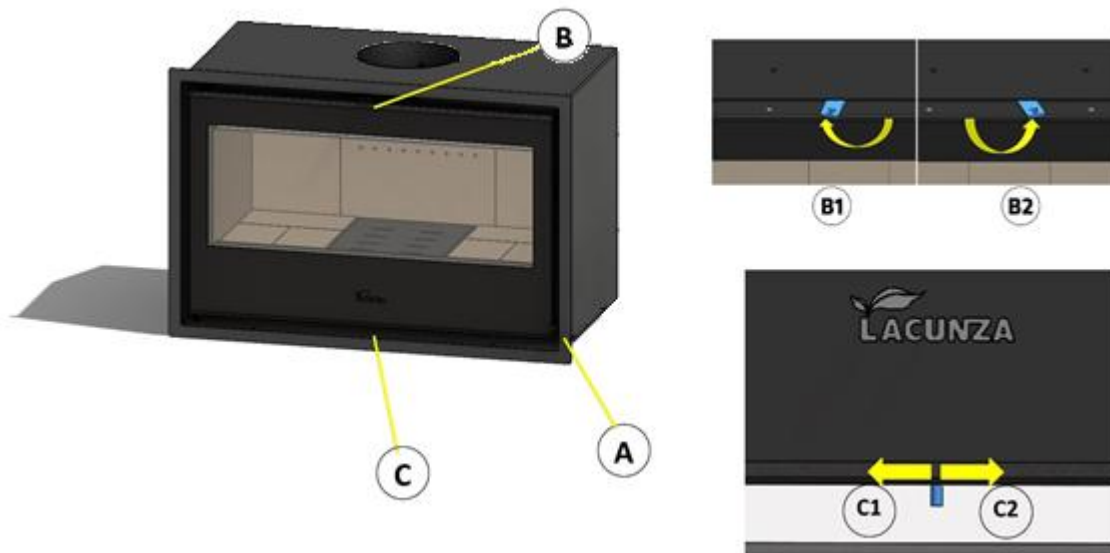

Figure No.6 - Operating components on the appliance

- A: Firebox door handle
- B: Secondary air intake
 - B1 closed (turn clockwise)
 - B2 open (turn anti-clockwise)
- C: Primary air intake
 - C1 open (right)
 - C2 closed (left)

3.3. Lighting

Use of the appliance in warm weather (warm days, early hours of the afternoon on sunny days) may lead to lighting and updraught problems.

Certain weather conditions, such as fog, ice, humidity entering the flue, etc., may hinder sufficient updraught in the flue and lead to suffocation.

Proceed as follows in order to light the appliance satisfactorily:

- Open the firebox door(s) and open all the firebox air-intake inlets to the full.
- Place paper or a firelighter and some wood chips in the firebox.
- Light the paper or firelighter.
- Leave the door slightly ajar, the width of two or three fingers, for about 15 minutes until the glass warms up.

3.4. Loading fuel

In order to load firewood, open the firebox door gently, preventing the sudden entry of air to the firebox so that smoke does not enter the room that the appliance is installed in. Perform this operation with the glove to prevent burns to the hands.

Always load with medium primary air settings (see table in section 1.1).

For minimum burning (e.g. at night), use thicker logs.

When the firebox is loaded, close the door.

Be careful when placing logs in the firebox on appliances with vermiculite interiors. Vermiculite is a fragile material and may crack if knocked.

3.5. Operation

The appliance should be operated with the door closed.

For safety reasons, never close all the appliance's combustion-air intakes.

Primary-air intake

By opening this inlet, air enters the firebox via the firebox grille.

Secondary-air intake

By opening this inlet, air enters the firebox via the top of the firebox door.

IMPORTANT: Keeping the secondary-air intake open helps keep the door glass cleaner for longer.

Double-combustion air intake

By opening this inlet, air enters the combustion flame, making for more efficient and less polluting combustion because post-combustion takes place, burning the particles which were not burned in the first combustion. This increases the performance of the appliance and reduces emissions.

In order to obtain maximum output, open all the air intakes to the firebox and in order to obtain minimum output, tend towards closing them.

For normal use, we recommend you close the Primary Intake (use this boost air supply for start-up only) and leave the Secondary open.

IMPORTANT: The appliance is exposed to extreme changes in temperature and may, as a result, make noises when in operation. These noises are a natural result of expansion/contraction of the parts which make up the appliance. Do not be alarmed by noises of this kind.

- (a) High burn rate: The appliance shall be operated with combustion rate controls fully open.
- (b) Low burn rate: The appliance shall be operated with all combustion rate controls adjusted to the minimum setting.
- (c) Medium burn rate: The appliance shall be operated with primary air intake closed and secondary air intake opened.

Lacunza recommends doing medium burn cycles.

3.6. Removing ash

Following sustained use of the appliance, it is necessary to remove the ash from the firebox. Remove the ashpit box when cold or using something to prevent yourself from getting burned (glove).

Never throw hot embers into the rubbish.

Access the ashpit by opening the door on the appliance.

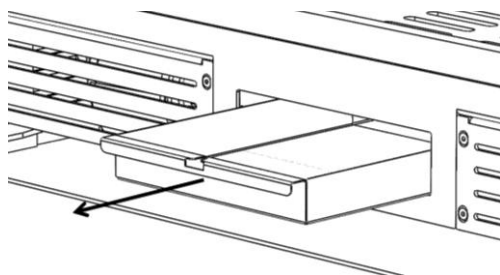

Figure No.7 - Remove ashpit.

Warning! It is very important to put the ashpit back in its housing at the bottom of the firebox after emptying it of ashes and before lighting the fire again! Do this by following the extraction process in reverse order.

3.7. Deflectors

The appliance has 2 vermiculite deflectors joined by a steel reinforcement and another steel deflector on top of the vermiculite.

Deflector Removal

First, the steel reinforcement must be removed. To do this, it must be pulled towards the front of the device, until it is released from the vermiculite pieces.

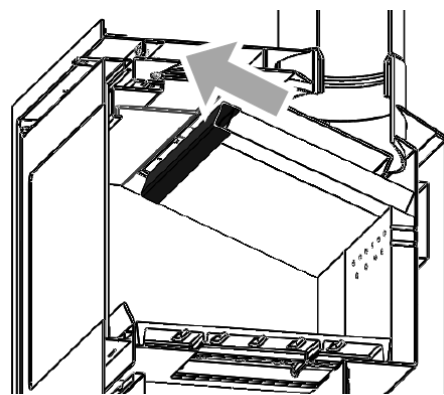

Figure No.8 - Dismantling the steel reinforcement.

Remove the vermiculite baffles as shown:

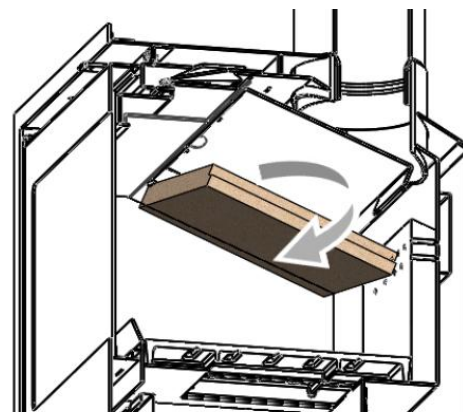

Figure No.9 - Extracción de los deflectores de vermiculita

We extract the rest of vermiculites from inside the device.

Rotate and remove the upper steel deflector.

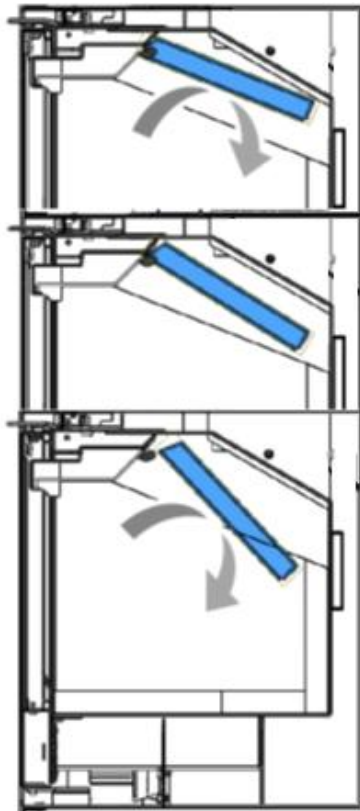

Figure No.10 - Girar y extraer el deflector superior de Acero

3.8. Electrical system (optional)

If you have the turbine kit, you should read the following instructions carefully.

Turbine-potentiometer connection

These are the connection instructions in order to control the ventilator system using the supplied potentiometer.



Figure No.11 - Connections to be carried out in the potentiometer

WARNING: The operating temperature of the potentiometer supplied by Lacunza is from 0 to 40°C. Particular care should be taken when choosing where it will be positioned so that it is not damaged by temperatures above 40°C. Insulate the potentiometer correctly so as to avoid this problem.

Read the potentiometer instructions for more information of connections.

Forced convection. Fans

Silver model with turbine kit has 2 fans for the forced convection of the hot air generated around the appliance inside the shell. This air can be piped to other rooms.

IMPORTANT: This appliance is not covered by our warranty unless directly connectet to the mains electricity supply in accordance with the conditions described in the relevant section in 1.1.

Potentiometer operation

The potentiometer controls the flow of hot air output from the appliance in automatic mode.

The fan automatically stars working at the set speed via the thermostat. When a fire has been lit in the firebox and the thermostat reaches a temperature of approximately 50°C, the fan starst working at the power set on the potentiometer and stops automatically when the temperature drosp beneath 50°C.

When the fans are working, they cannot be switched off manually, only their speed can be changed.

Read the potentiometer instructions for more information of connections.

4. MAINTENANCE AND IMPORTANT ADVICE

4.1. Maintenance of the appliance

The appliance, the flue connector piping and the flue must be cleaned regularly, particularly following long periods without use.

4.1.1. Firebox

Clean the firebox area of ash, etc.

4.1.2. Inside the appliance

Clean the firebox area of ash. Clean the deflectors, where soot may build up.

4.1.3. Flue socket

The flue socket area must be kept clean at all times for the appliance to work properly.

It must be cleaned as often as required. How often it is cleaned depends on how much the appliance is used and the type of fuel employed.

4.1.4. Firebox glass

To keep the glass as clean as possible for as long as possible, the secondary air register should be kept open. However, over the hours of use, the glass may become dirty. To clean it, we will use specific degreasing products or dry cleaning products for this task.

The cleaning should be carried out with the glass cold and taking care not to apply the glass cleaner directly on the glass as, if it comes into contact with the door's closing cord, it may deteriorate. Put the cleaning product on the cloth.

It is also important to prevent the cleaning liquid from getting into the moving mechanism of the register, as this could jam it.

Caution, the vitro ceramic glass is prepared to support 700°C. Never let burning woods or combustion flame beating against the glass for prolonged periods of time. In this case, the glass would be submit to temperatures above 750°C, this could change the internal structure of the glass and make it opaque (irreversible phenomenon).

Attention, never let the product drip into the lower part of the glass. The accumulation of the cleaning product, with soot or ash residues, can damage the screen printing on the glass.

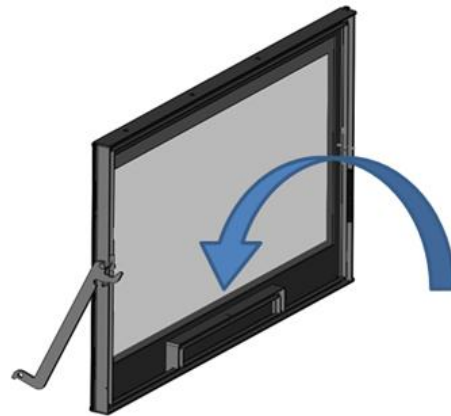

Note: If we use the appliance in draught conditions higher than 15Pa or burn more wood (per hour) than those indicated in table 1.1, we will subject the appliance to working conditions higher than those designed for it. This can lead to aggressive fouling of the glass (white halo), which cannot be cleaned by the traditional method.

4.1.5. Painted sheet-steel-cast-iron parts.

These parts should be cleaned with a brush or dry cloth. Do not dampen the parts: the steel could rust and the paint could blister and chip. Be particularly careful when cleaning the glass: the liquids used must not dampen the painted steel.

4.1.6. Air intake registers

In the air intake for combustion registers, remains of ash, sawdust, cleaning fluids, etc. may accumulate, which restrict or hinder its movement. In these cases, they should be released and cleaned.

4.2. Maintenance of the chimney flue

VERY IMPORTANT: In order to avoid incidents (chimney fires, etc.), it is necessary to perform maintenance and cleaning operations on a regular basis; if the appliance is used often, then the chimney and the flue connector piping must be swept several times a year.

In the event of fire in the chimney, close the flue draught, close doors and windows, remove embers from the firebox,

block the connection hole with damp cloths and call the fire brigade.

4.3. Important advice

Lacunza recommends that only Lacunza-authorized replacement parts be used.

Lacunza accepts no liability for any modification to the product which it has not authorised.





This appliance is a heat-producing appliance and contact may lead to burns.

<p>This appliance may remain HOT for a period of time after it has gone out. MAKE SURE THAT SMALL CHILDREN DO NOT GO NEAR IT.</p>

5. TROUBLESHOOTING



This symbol means that a qualified professional should be called to perform the operation.

Problem	Probable causes		Solution
The fire does not light properly The fire does not stay alight	Green or damp wood		Use hard woods, cut at least 2 years ago and stored in a sheltered, ventilated place
	The logs are too large		Use crumpled paper or firelighters and dry wood chips to light the fire. Use split logs to keep the fire going
	Poor-quality wood		Use hard woods which produce heat and embers (chestnut, ash, maple, birch, elm, beech, etc.)
	Insufficient primary air		Open the primary- and secondary-air intakes completely, or even open the door slightly. Open the outdoor-air inlet grille
	Insufficient updraught		Check that the draught is not blocked. De-soot if necessary. Check that the flue is in perfect condition (airtight, insulated, dry, etc.)
The fire flames up too much	Excessive primary air		Close the primary- and secondary-air intakes partially or totally
	Excessive updraught		Install a draught damper
Smoke given off on lighting	Poor-quality wood		Do not continually burn chips, carpentry scraps (plywood, pallets, etc.)
	Cold flue		Heat up the flue by burning a piece of paper in the firebox.
Smoke during burning	The room is at low pressure		In rooms with Controlled Mechanical Ventilation, leave an outdoor window ajar until the fire is fully alight.
	Too little wood loaded		Load as recommended. Loads notably smaller than those recommended lead to low smoke temperature and downdraught.
	Insufficient updraught		Check the condition of the flue and insulation. Check that the piping is not blocked. Clean mechanically if necessary
	Wind enters the flue		Install an anti-downdraught system (Cowl) at the top of the chimney
Does not warm up enough	The room is at low pressure		In rooms with Controlled Mechanical Ventilation, there must be an outdoor-air inlet
	Poor-quality wood		Only use the recommended fuel
Water condenses (after the appliance has been lit more than 3 or 4 times)	Too little wood loaded		Load as recommended. Loads notably smaller than those recommended lead to low smoke temperature and condensation.
	Green or damp wood		Use hard woods, cut at least 2 years ago and stored in a sheltered, ventilated place.
	Condition of the flue		Lengthen the flue (5-6 metres minimum). Insulate the flue properly. Check the airtightness of the flue/appliance.

6. BASIC BREAKDOWNS

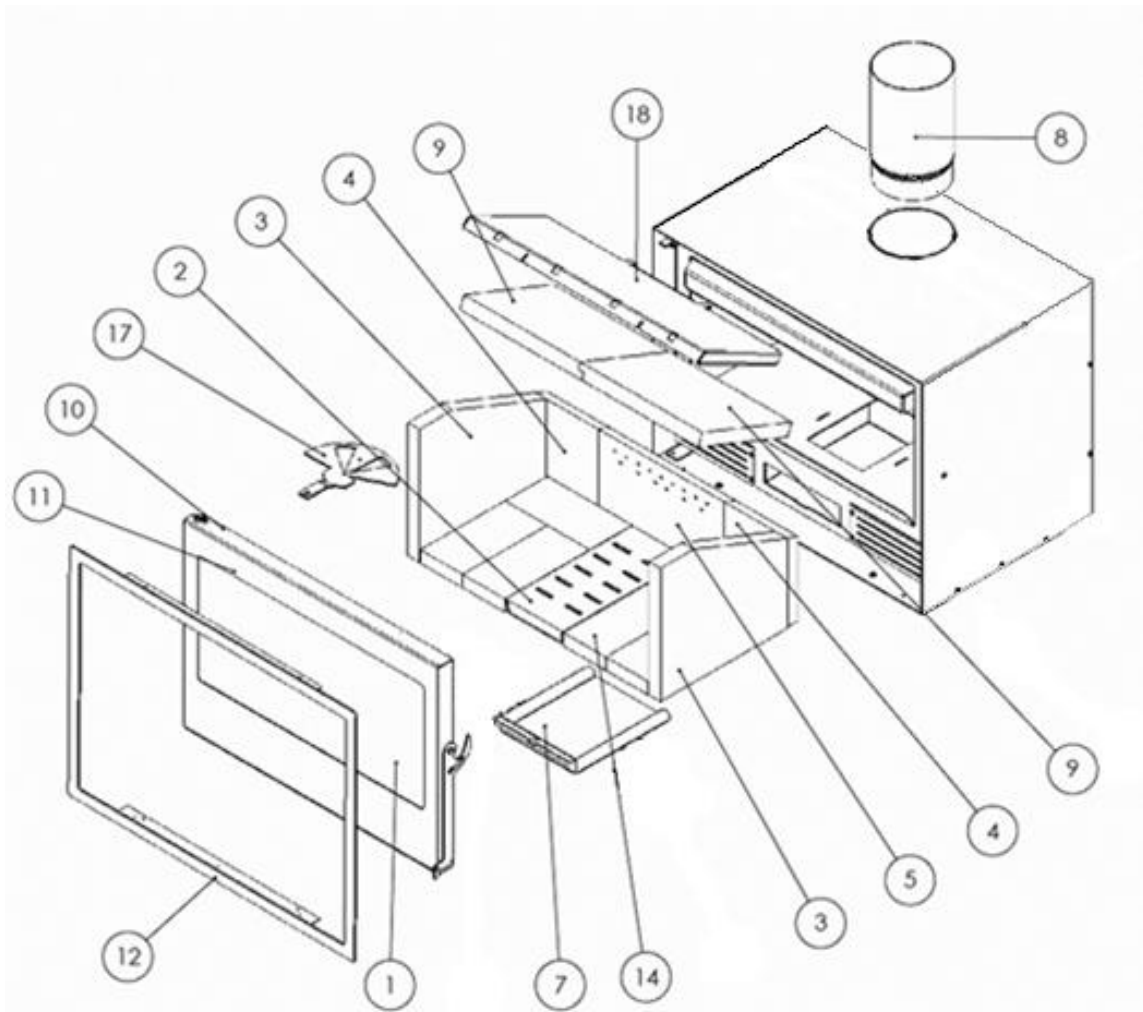

Nº	Reference	Description	Qty.
1	500000000857	SILVER-GOLD-ROCK 800 GLASS	1
	500000000858	SILVER-GOLD-ROCK 1000 GLASS	1
2	5040000897	SILVER-GOLD-ROCK PLUS 800 GRATE	1
	5040000898	SILVER-GOLD-ROCK PLUS 1000 GRATE	2
3	500000000862	SILVER-GOLD-ROCK VERMICULITE SIDE PANEL	2
4	5040000891	SILVER-GOLD-ROCK PLUS 800 VERMICULITE REAR SIDE PANEL	2
	5040000892	SILVER-GOLD-ROCK PLUS 1000 VERMICULITE REAR SIDE PANEL	2
5	5040000893	SILVER-GOLD-ROCK PLUS VERMICULITE CENTRAL REAR PANEL	1
7	502570000000	OCEAN-ATLANTIC-SILVER-GOLD-ROCK-PLATINUM ASH TRAY	1
8	5000000840	150mm DIAMETER AND 250mm LENGTH TUBE (Silver 700 Plus)	1
	5000000841	200mm DIAMETER AND 250mm LENGTH TUBE (Silver 800 y 1000 Plus)	1
9	5040000900	SILVER GOLD-ROCK 800 PLUS VERMICULITE DEFLECTOR	2
	5040000901	SILVER GOLD-ROCK 1000 PLUS VERMICULITE DEFLECTOR	2
10	509020000042	BLACK CERAMIC FIBER CORD Ø13mm	4m
11	500000000510	FLAT HAIR CORD 8x2mm	4 m
12	504400000002	SILVER 800 PLUS FRAME	1
	504410000002	SILVER 1000 PLUS FRAME	1
14	504000000838	REFRACTORY 220X110X30 (SILVER GOLD ROCK 800 PLUS)	6
	504000000838	REFRACTORY 220X110X30 (SILVER GOLD ROCK 1000 PLUS)	8
15	5000000947	DEFLECTOR SUPPORT (SILVER GOLD ROCK 800 PLUS)	1
	5000000948	DEFLECTOR SUPPORT (SILVER GOLD ROCK 1000 PLUS)	1
17	504390000007	SILVER-GOLD-ROCK SECONDARY REGISTER	1
18	50440000008	SECOND DEFLECTOR (SILVER GOLD ROCK 800 PLUS)	1
	50441000007	SECOND DEFLECTOR (SILVER GOLD ROCK 1000 PLUS)	1

7. CERTIFICATE OF COMPLIANCE



Certificate of Compliance for **SOLID FUEL HEATERS**

This is to certify that the appliance stated on this certificate has been tested for Thermal Clearances, Heat Output, Thermal Efficiency and Particulate Emissions in accordance with the Australian / New Zealand Standard(s) detailed below

<i>Manufacturer</i>	Lacunza
<i>Make</i>	Lacunza
<i>Model</i>	Silver 800 Plus
<i>Type</i>	Free-Standing/Insert/Inbuilt
<i>Category</i>	Slow combustion Wood Heater
<i>Fuel Type</i>	Hardwood
<i>Test Report No's:</i>	ASFT22005-1 ASFT22009-1
<i>Maximum Avg Heat Output</i>	6.7kW
<i>Overall Avg Efficiency</i>	70%
<i>Particulate Emissions Factor</i>	0.9g/kg
<i>National Standards</i>	AS/NZS 4012 (2025) AS/NZS 4013 (2025) AS/NZS 2918 (2018)

ASFT hereby grants to:

Lacunza

of
31800 Alsasua / Navarra SPAIN

Certificate No.: **ASFT25C057**
Issue Date: **7 August 2025**

Certified Date: **24 February 2022**
Expiry Date: **20 June 2035**

Steve Marland

Managing Director of ASFT

ASFT performs compliance testing of Solid Fuel Appliances to the relevant Australian/New Zealand standards. This certification is subject to the conditions set forth in the characteristics above and is not to be construed as any recommendation, assurance or guarantee by ASFT of the product acceptance by Authorities having jurisdiction.



Certificate of Compliance for **SOLID FUEL HEATERS**

This is to certify that the appliance stated on this certificate has been tested for Thermal Clearances, Heat Output, Thermal Efficiency and Particulate Emissions in accordance with the Australian / New Zealand Standard(s) detailed below

<i>Manufacturer</i>	Lacunza
<i>Make</i>	Lacunza
<i>Model</i>	Silver 1000 Plus
<i>Type</i>	Free-Standing
<i>Category</i>	Slow combustion Wood Heater
<i>Fuel Type</i>	Hardwood
<i>Test Report No's:</i>	ASFT21061-1 ASFT21062-1
<i>Maximum Avg Heat Output</i>	7.9kW
<i>Overall Avg Efficiency</i>	65%
<i>Particulate Emissions Factor</i>	0.7g/kg
<i>National Standards</i>	AS/NZS 4012 (2025) AS/NZS 4013 (2025) AS/NZS 2918 (2018)

ASFT hereby grants to:

Lacunza

of
31800 Alsasua / Navarra SPAIN

Certificate No.: **ASFT25C058**
Issue Date: **7 August 2025**

Certified Date: **3 September 2021**
Expiry Date: **20 June 2035**

Steve Marland

Managing Director of ASFT

ASFT performs compliance testing of Solid Fuel Appliances to the relevant Australian/New Zealand standards. This certification is subject to the conditions set forth in the characteristics above and is not to be construed as any recommendation, assurance or guarantee by ASFT of the product acceptance by Authorities having jurisdiction.



Certificate of Compliance

for

SOLID FUEL HEATERS

This is to certify that the appliance stated on this certificate has been tested for Thermal Clearances, Heat Output, Thermal Efficiency and Particulate Emissions in accordance with the Australian / New Zealand Standard(s) detailed below

<i>Manufacturer</i>	Lacunza
<i>Make</i>	Lacunza
<i>Model</i>	Silver 1000 Plus
<i>Type</i>	Insert/Inbuilt appliance
<i>Category</i>	Slow combustion Wood Heater
<i>Fuel Type</i>	Hardwood
<i>Test Report No's:</i>	ASFT21061-1 ASFT22035-2
<i>Maximum Avg Heat Output</i>	7.9kW
<i>Overall Avg Efficiency</i>	65%
<i>Particulate Emissions Factor</i>	0.7g/kg
<i>National Standards</i>	AS/NZS 4012 (2025) AS/NZS 4013 (2025) AS/NZS 2918 (2018)

ASFT hereby grants to:

Lacunza

of

31800 Alsasua / Navarra SPAIN

Certificate No.: **ASFT25C144**

Certified Date: **6 December 2024**

Issue Date: **24 November 2025**

Expiry Date: **20 June 2035**

Steve Marland

Managing Director of ASFT

ASFT performs compliance testing of Solid Fuel Appliances to the relevant Australian/New Zealand standards. This certification is subject to the conditions set forth in the characteristics above and is not to be construed as any recommendation, assurance or guarantee by ASFT of the product acceptance by Authorities having jurisdiction.

LACUNZA KALOR GROUP S.A.L

Pol. Ind. Ibarrea 5A

31800 Alsasua (Navarra) Spain

Tel.: (00 34) 948 56 35 11

Fax.: (00 34) 948 56 35 05

e-mail: comercial@lacunza.net

Website: www.lacunza.net

EDITION: 14

