

# DFS Series

GAS FIREPLACE

## Installation & Service Instructions

**IMPORTANT: THESE DF700 AND DF960 FIRES REQUIRE THE USE OF A 43MM RESTRICTOR ON THE UVP POWERFLUE INTAKE PIPE (REFER TO SECTION C4 AND C5).**

**IMPORTANT: THE FASCIA AND SECONDARY GLASS ARE CRITICAL COMPONENTS OF THE FIRE AND MUST BE PROPERLY FASTENED PRIOR TO RUNNING THE FIRE (REFER TO SECTIONS D2 AND F1).**

**IMPORTANT: KEEP THIS MANUAL AND ANY OTHER INSTRUCTION SHEETS THAT COME WITH YOUR FUELBED AS THEY CONTAIN NECESSARY INFORMATION FOR FUTURE SERVICING**

**IMPORTANT:**

The appliance shall be installed in accordance with;

- This installation instruction booklet
- Local gas fitting regulations
- Municipal building codes
- Electrical wiring regulations
- Any other relevant statutory regulations.
- AS/NZS 5601.1 Gas Installations

**WARNING:**

**THIS APPLIANCE MUST BE INSTALLED BY A QUALIFIED PERSON. THIS APPLIANCE MUST BE INSTALLED STRICTLY IN ACCORDANCE WITH THE FOLLOWING INSTRUCTIONS.**

**DO NOT SPRAY AEROSOLS IN THE VICINITY OF THIS APPLIANCE WHILE IT IS IN OPERATION.**

**DO NOT USE OR STORE FLAMMABLE MATERIALS IN OR NEAR THIS APPLIANCE.**

**DO NOT PLACE ARTICLES ON OR AGAINST THIS APPLIANCE.**

**DO NOT MODIFY THIS APPLIANCE.**

This appliance is not intended for use by young children or infirm persons unless they have been adequately supervised by a responsible person to ensure that they can use the appliance safely.

Young children should be supervised to ensure that they do not play with the appliance. Failure to follow these instructions could cause a malfunction of the heater, which could result in death, serious bodily injury, and/or property damage. Failure to follow these instructions may also void your fire insurance and/or warranty.

**Who can install this product:**

Installation must be carried out by a registered installer who, on completion of the installation, must issue a:

AUS: Certificate of Compliance

NZ: Certificates that comply with the latest legislation in accordance with national and/or local codes. If these are not issued then the Escea warranty may be void.

**Warranty Repair and Annual Servicing:**

Please contact Escea if you require warranty work. Warranty repair work must be carried out by a recognised gas fire technician. It is recommended that recognised Escea Gas Fire Technicians are also used to carry out annual servicing requirements (particularly during the warranty period). For contact details of recognised Escea Gas Fire Technicians in your area, or for replacement parts, please contact the retailer from whom the appliance was purchased or visit our website.

To progress any warranty claims for damaged appliances/parts, photographic evidence may be required. Providing this can help contribute to a timelier resolution of a claim.

The heater must be installed according to these instructions and in compliance with all relevant building, gas fitting, electrical and other statutory regulations (e.g.. AS/NZS 5601). Any shortcomings in the appliance and flue installation will be the responsibility of the installer, and Escea will not be accountable for any such failings or their consequences.

Manufactured by: Escea Ltd, PO Box 5277 Dunedin NZ, Ph: +64 3 478 8220

For contact details of your local Escea distributor or dealer please visit [www.escea.com](http://www.escea.com) or email: [info@escea.com](mailto:info@escea.com). From Australia, visit [www.escea.com.au](http://www.escea.com.au) or call: AUS : 1-800 460 832

## CONTENTS

<b>A Product Description and Installation Process</b>		<b>4</b>
<hr/>		
A1	Product Description	4
A2	Recommended Install Process	4
<b>B Positioning the Unit</b>		<b>7</b>
<hr/>		
B1	Removing the Fascia	7
B2	Removing panels to ease installation	7
B3	Unit Dimensions	8
B4	Corner Installations	10
B5	Hearth	10
B6	Rear & Side Wall Clearances	11
B7	Television & Items	11
<b>C Installing the Flue</b>		<b>12</b>
<hr/>		
C1	Flue Configuration (if less than 4m is required)	12
C2	Flue Configuration (if more than 4m is required)	13
C3	Installing the Horizontal Power Flue	13
C4	Installing the External Vertical Power Flue (UVP)	16
C5	Installing the Internal Vertical Power Flue	17
C6	Installing in Accordance with Relevant Codes	19
C7	Running the Flue	20
C8	Running the Power Flue Electrical Cable	20
C9	Setting up the Flue Spigot Plate	21
<b>D Installing the Electricity and Gas to the Appliance</b>		<b>22</b>
<hr/>		
D1	Power Supply	22
D2	Removing the Glass	22
D3	Removing the Burners	23
D4	Gas Pipe Sizing	24
D5	Gas Pipe Position	24
D6	Gas Supply	24
<b>E Installing The Appliance</b>		<b>25</b>
<hr/>		
E1	Securing the Unit	25
E2	Routing the PowerFlue and Power Cable	26
E3	Connecting the Flue	26
E4	Move to the Main Manual	27
E5	Fascia Alignment Guide	27
<b>F Installation Checklist</b>		<b>28</b>
<hr/>		

# A PRODUCT DESCRIPTION AND INSTALLATION PROCESS

---

## A1 Product Description

The Escea DFS console is a free standing unit designed to house the DF700 or DF960 gas fireplaces without the need for a cavity or masonry surround.

These appliances are flued using co-linear flexible aluminum flue (with PolyPro flue extensions for some models) connected to a Power Flue. The user will control their fire with the bluetooth remote that will normally be located in its wall mount cradle. In addition to the bluetooth remote the appliance has a single auxiliary On/Off button on the unit. When not in operation it is in a standby mode unless it is physically isolated from the mains supply.

For the DFS740 and DFS940 a GRC (Glassfibre-Reinforced Concrete) plinth is available for purchase to compliment these Freestanding units.

## A2 Recommended Install Process

The following diagrams on the next two pages illustrate the steps required to install your gas fire. The sequence in which you choose to do these tasks will vary depending on your individual scenario. Please read these instructions fully before proceeding with the installation.

**IMPORTANT: INSTALLATIONS THAT ARE NOT SPECIFICALLY OUTLINED IN THIS MANUAL SHOULD BE REFERRED TO THE ESCEA ARCHITECTURAL ADVISORY TEAM.**

**PLEASE EMAIL [AA@ESCEA.COM](mailto:AA@ESCEA.COM)**

**I.E. DF FLUE INSTALLATIONS OVER 4 METRES.**

**To ensure that your installation is fully complete, please use the "Installation Checklist" on page 28.**

## DFS730 Installation

### 1. Removing Panels and installing fluing

- Locate the freestanding console in the desired location, complying with all clearances. Allow for an electrical outlet within 1m.
- Secure the freestanding console to the floor or base.
- Remove the console lid and fascia and set aside.
- Install the black rigid liners to the console, installing the ceiling plate temporarily above the fireplace.
- Run the twin flexible flue pipes and the powerflue electrical cable. Connect the powerflue electrical cable at the flue terminal. The powerflue cable must be away from the exhaust flue within the rigid liner.

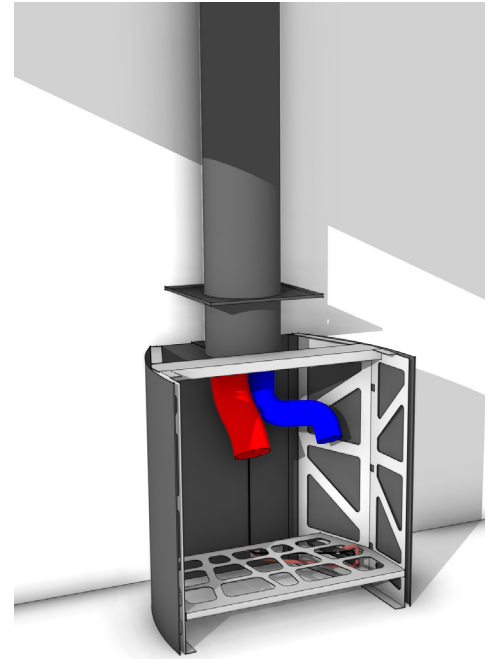

### 2. Install the Fire

- Install the DF700 fireplace into the freestanding console, connecting the flue pipes to the flue spigot plate on the fireplace.
- Connect gas supply and the powerflue electrical cable.
- Connect power supply to wall outlet.
- Complete commissioning of the fireplace and flue.

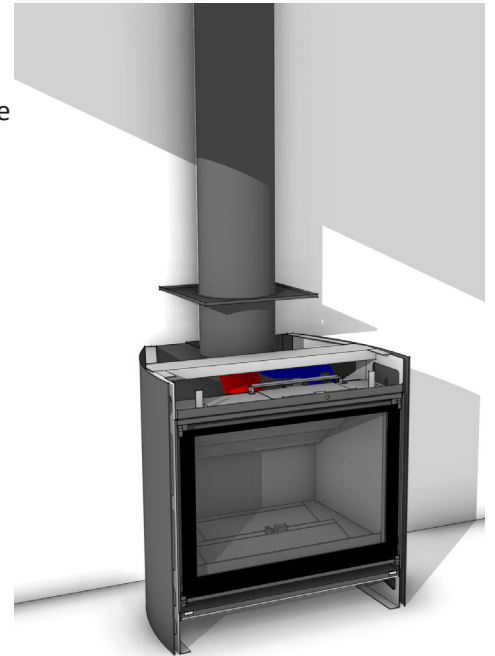

### 3. Finish installation, fit the fascia and test appliance

- Fit the fascia and lid components back to the console.
- Install the ceiling plate to cover the hole in the ceiling around the flue liner.
- Complete the project with any remaining fixtures and finishes.

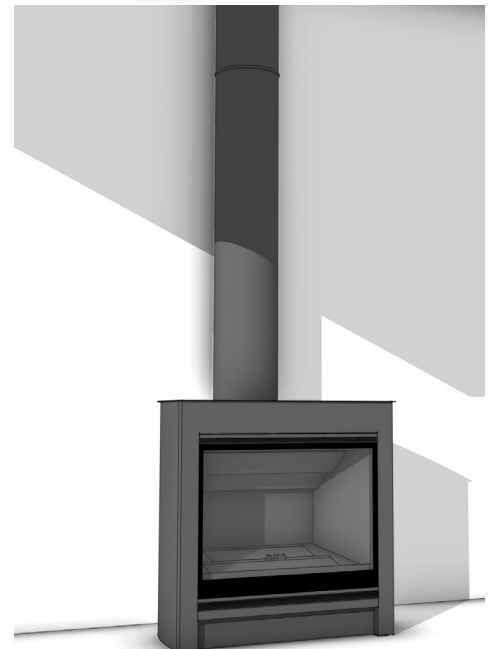

## DFS740 & 940 Installation

### 1. Install the console, fluing, and services.

- Locate the freestanding console in the desired location, complying with all clearances. Allow for an electrical outlet within 1m.
- Secure the freestanding console to the floor or base.
- Remove the flue spigot plate from the fireplace.
- Install the black rigid liners to the console, installing the ceiling plate temporarily above the fireplace.
- Run the twin flexible flue pipes and connect them to the removable flue spigot plate. Connect the powerflue electrical cable at the flue terminal. The powerflue cable must be away from the exhaust flue within the rigid liner.

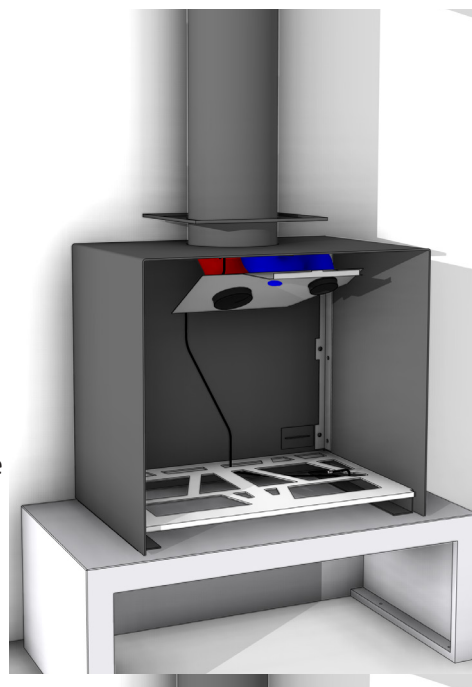

### 2. Install Fire

- Install the DF700 fireplace into the freestanding console connecting the flue spigot plate back onto the fireplace.
- Connect gas supply and the powerflue electrical cable.
- Connect power supply to wall outlet.
- Complete commissioning of the fireplace and flue.

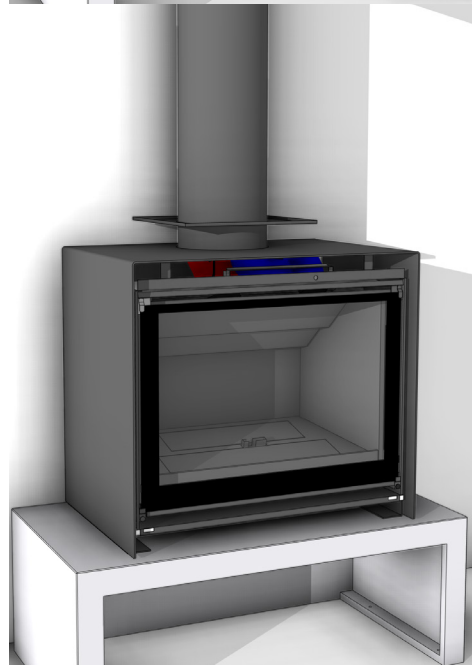

### 3. Finish installation, fit the fascia, and test appliance

- Fit the fascia components back to the console.
- Install the ceiling plate to cover the hole in the ceiling around the flue liner.
- Complete the project with any remaining fixtures and finishes.

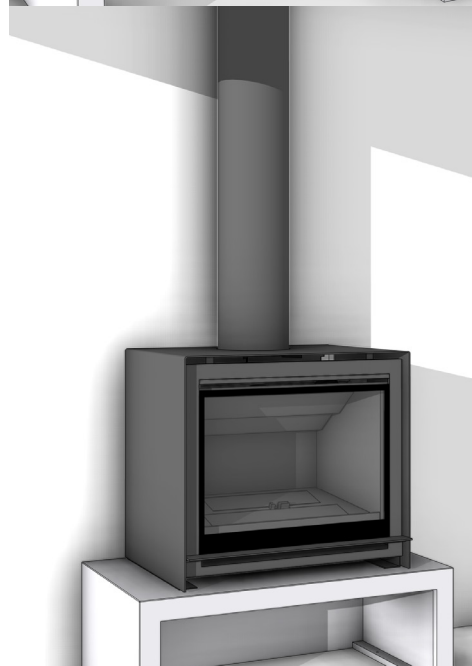

# B POSITIONING THE UNIT

---

## B1 Removing the Fascia

The Fascia will need to be removed to install the flue onto the spigot plate in section "C9 Setting up the Flue Spigot Plate" on page 21. On the DFS730 this can be done by removing the 2 screws on either side at the top of the fascia and then pulling off gently. For the DFS740 and 940 the fascia is already separate to the unit on shipping.

## B2 Removing panels to ease installation

To ease the installation process some of the panels on the DFS units can be removed.

### DFS740 and 940

The back panel of these Units can be removed. To do this remove all of the bolts holding the back panel on and then remove the panel.

### DFS730

The DFS730 has the option of removing the lid and the back panel, to remove the lid undo the two screws circled below and pull the lid up, this is held on by magnets.

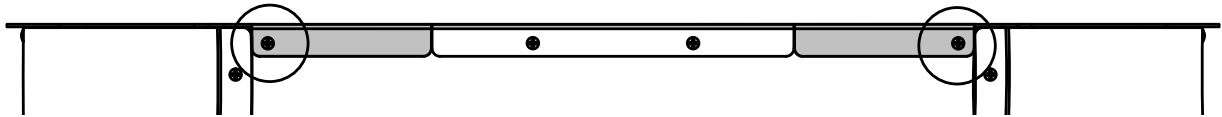

To remove the back panel undo the screws circled below and pull away from the unit, this will have a small section of the lid still attached.

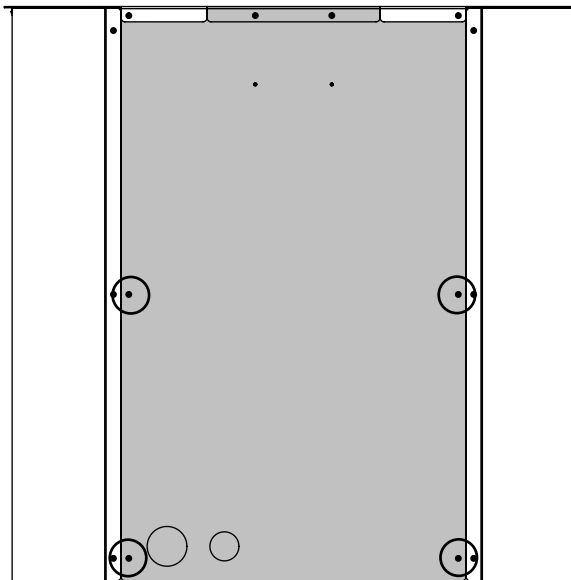

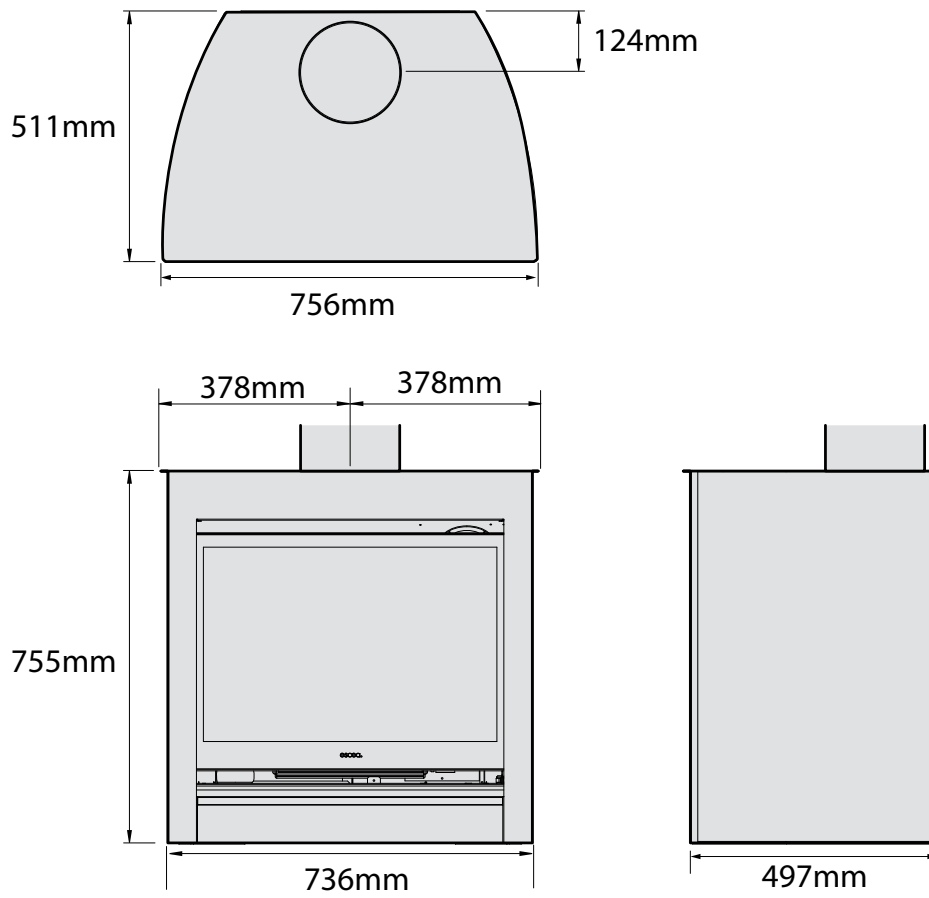
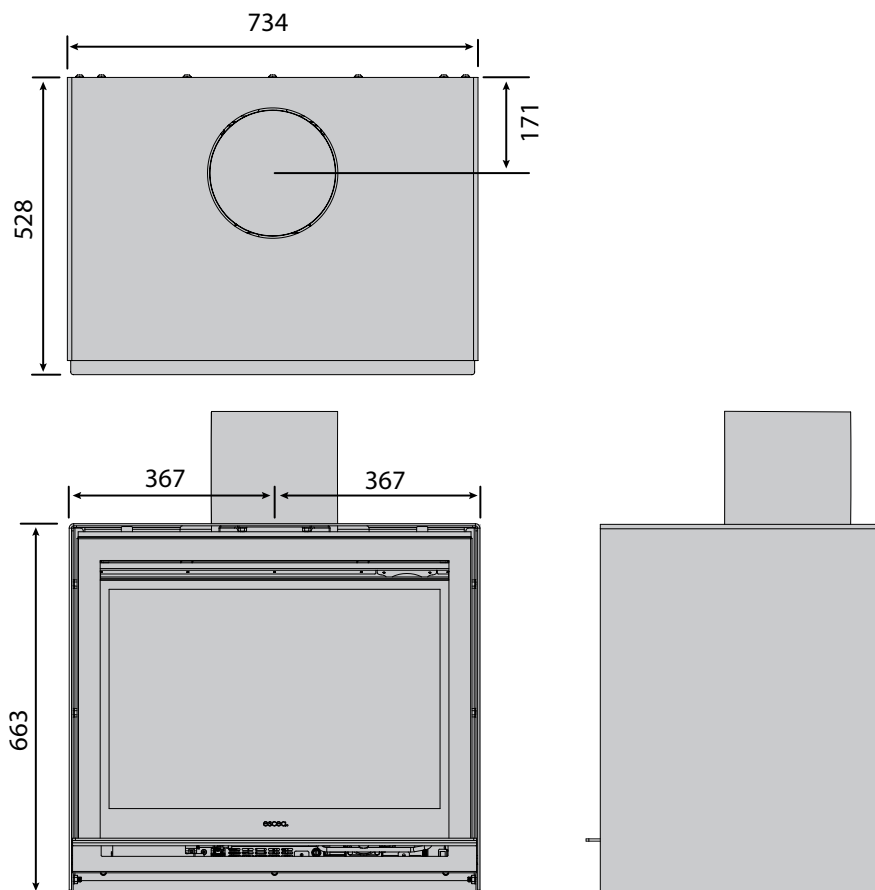
**B3 Unit Dimensions****DFS730****DFS740**

DFS940

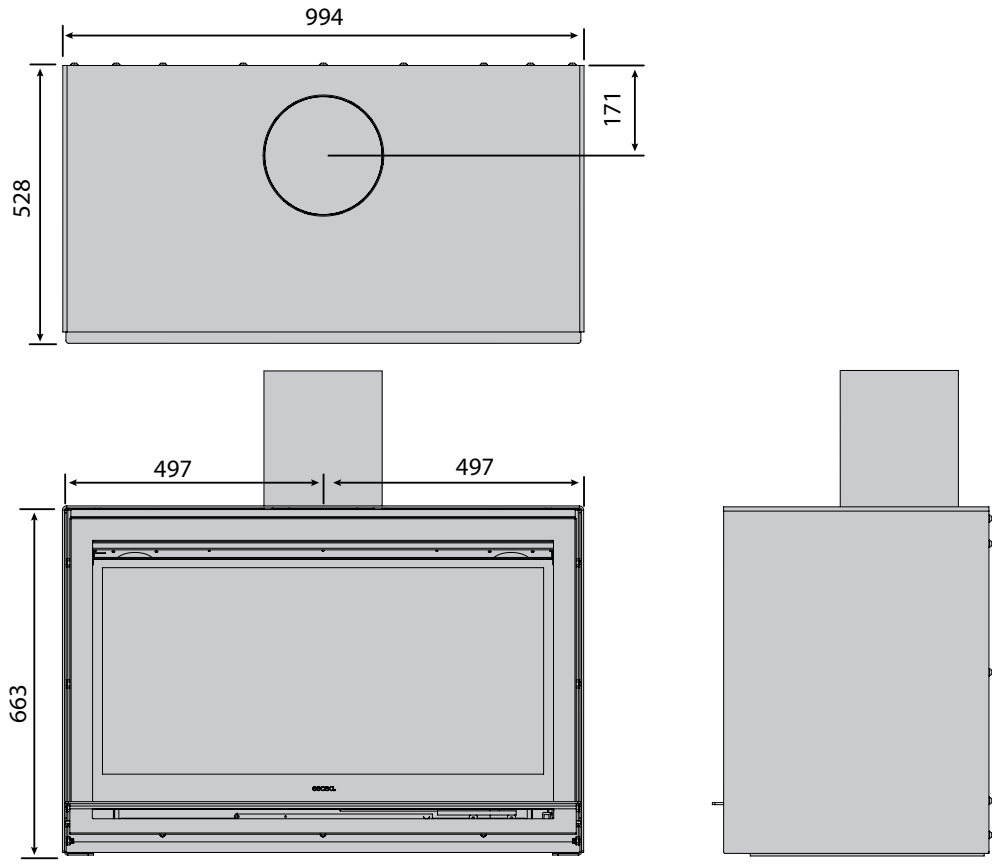

GRC Plinth (DFS740 and 940 Only)

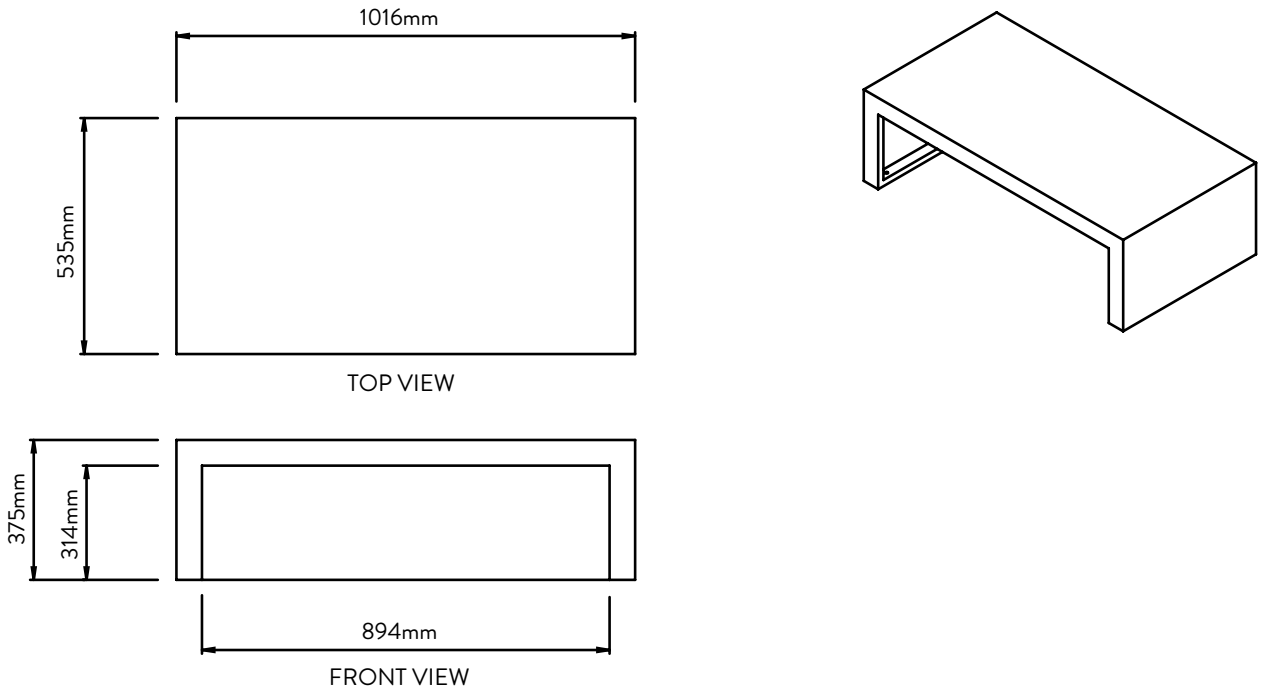

## B4 Corner Installations

If a unit is to be installed in a corner, the following drawings give the minimum distance from interior walls.

DFS730

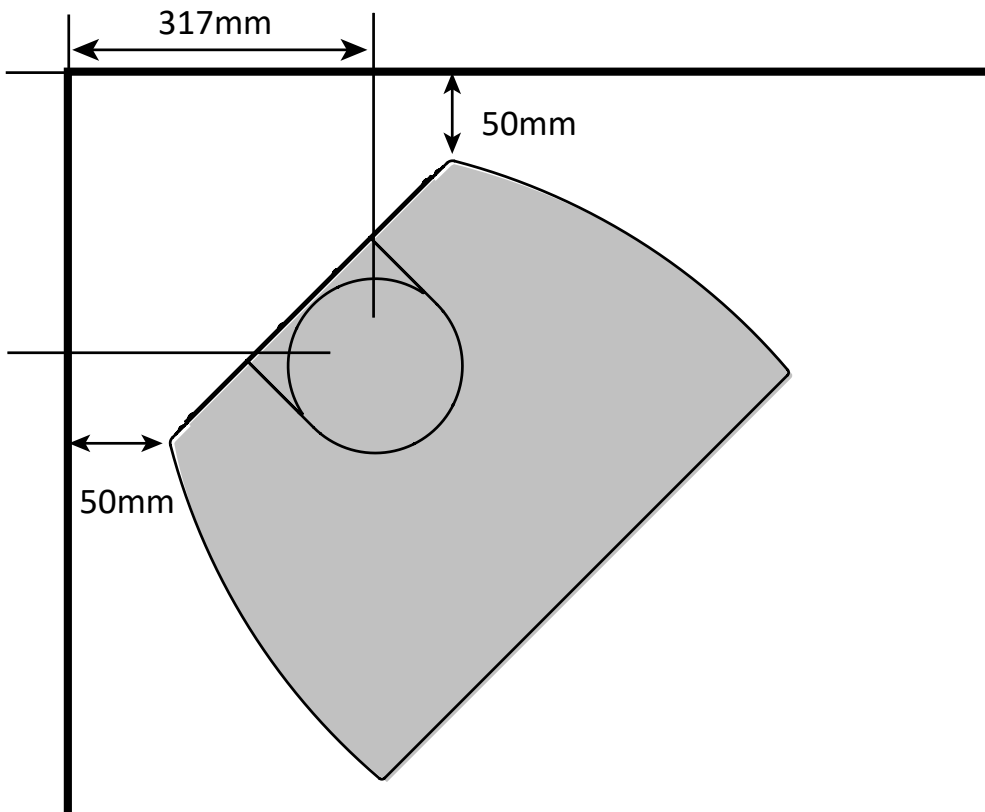

**DFS740**

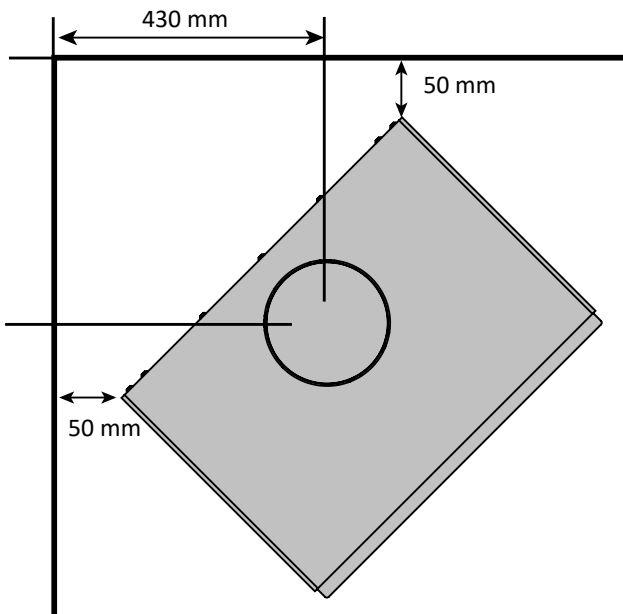

**DFS940**

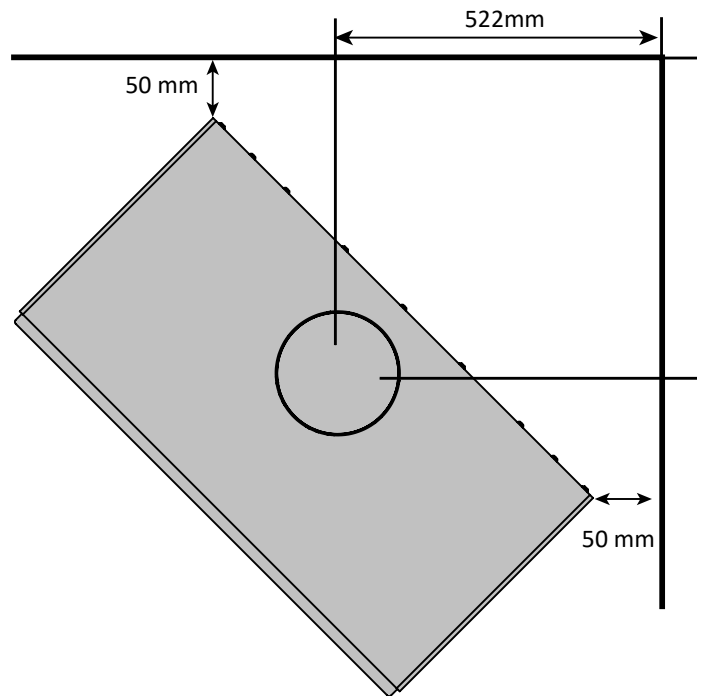

## B5 Hearth

A finished floor level hearth is not required, however it may be used for decorative purposes or for protection of flooring.

## B6 Rear & Side Wall Clearances

The diagram (shown below) shows the recommended minimum clearances for the location of any DFS Series Unit in relation to a side wall.

*NOTE: The distance increases when the side wall extends forward of the fireplace.*

### DFS730

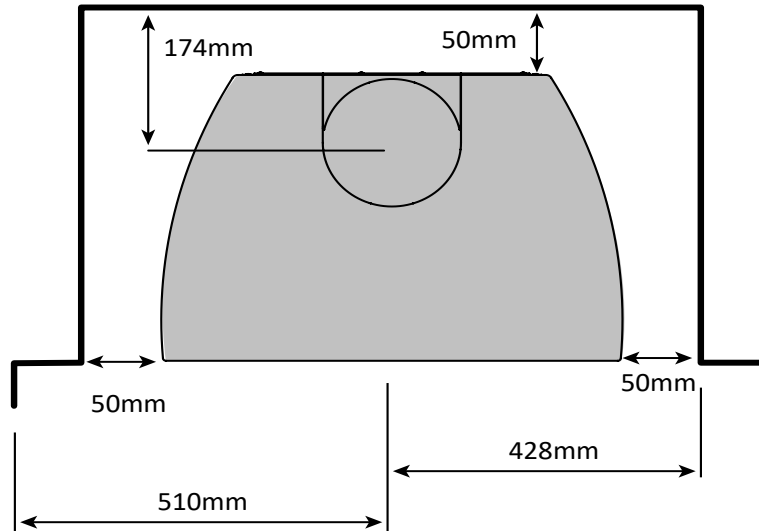

### DFS740 & 940

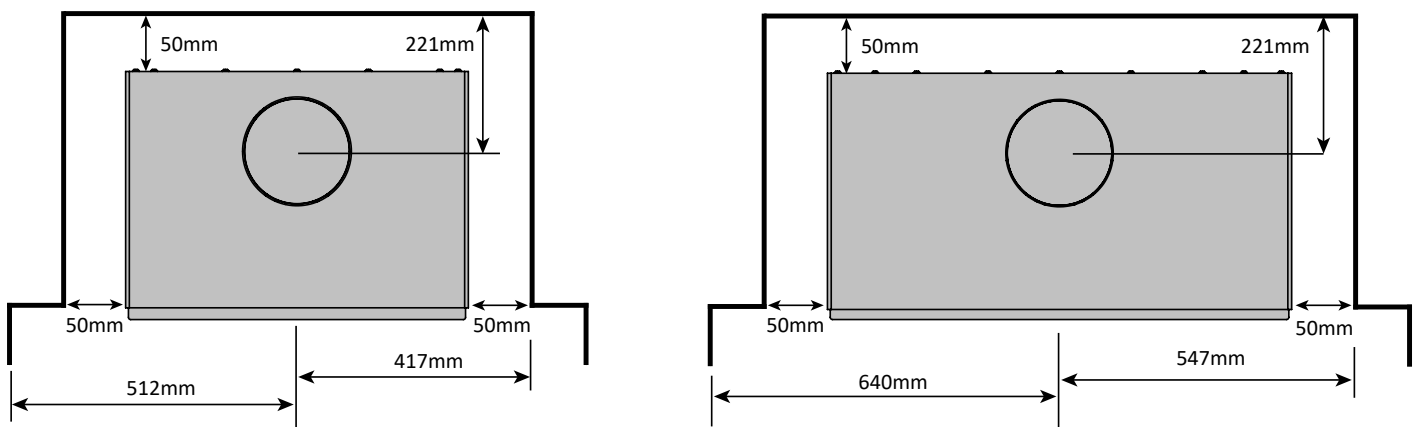

*NOTE: If a GRC plinth is being used as a base for a DFS740 or DFS940, clearances must still be adhered to.*

## B7 Television & Items

**DO NOT PLACE ITEMS OR FURNISHINGS ON TOP OF THE FREESTANDING FIREPLACE, AND ENSURE SOFT FURNISHINGS DO NOT COME IN CONTACT WITH THE FREESTANDING FIREPLACE.**

### END OF SECTION B

BY THE END OF THIS SECTION, YOU SHOULD HAVE:

- A suitable space for the DFS console to be installed

# C INSTALLING THE FLUE

## C1 Flue Configuration (if less than 4m is required)

For vertical installs the black flue liner will accommodate the flexiflue pipes for the initial section of the run until the penetration of the ceiling, once in the roof space the flue liner is not necessary, leave 50mm of liner in the roof space if cutting the flue liner.

Once in the ceiling the flexifluing can go horizontally or continue vertically as long as the run does not exceed 4m.

For horizontal installs the black flue liner and right angle connection will accommodate the flexiflue pipes all the way to the horizontal powerflue

*NOTE: The fan in this powerflue produces 52 DB of noise, think carefully around the location of the terminal, if the terminal is in close proximity to the fire then the fan noise will be more prevalent. If the only option is to install the terminal close to the fire then introducing sound deadening material around the back of the terminal or stretching out the flexiflue and adding more S-bends is recommended to reduce sound transfer through to the fire.*

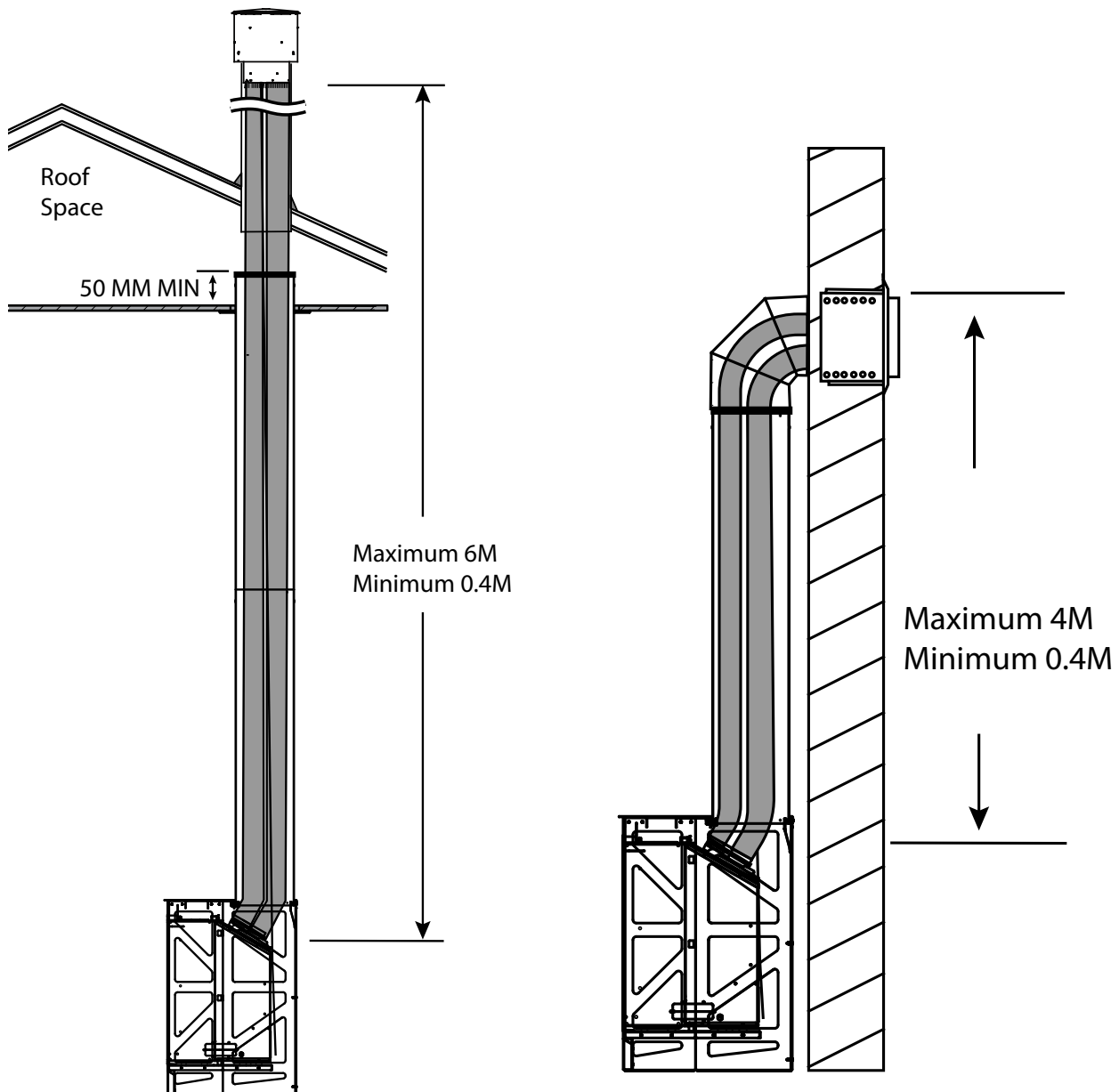

## C2 Flue Configuration (if more than 4m is required)

If your flue system is greater than 4m long then there is the option of using Flexible flueing with a condensate trap and rigid PolyPro tube lengths.

Please contact the Architectural Advisory Team for more information.

- AA@escea.com

## C3 Installing the Horizontal Power Flue

*Note: The appliance is designed only to operate using the approved flexible or PolyPro flue supplied by Escea. Other brands of flue may not fit, and this will affect the appliance warranty.*

The Horizontal Power Flue Wall Terminal must be installed in the correct orientation (the small horizontal slot should be at the bottom). This allows for the correct operation of the flue system and prevents the ingress of water.

The Horizontal Power Flue Wall Terminal must be weather tight when installation is complete to prevent damage to the dwelling. It must be installed by a suitably qualified person.

Fit the Horizontal Power Flue Wall Terminal into the hole and fix in place, making sure the installation is sealed appropriately to prevent the ingress of water from outside the wall cladding. Take notice of the label on the termination which shows the correct orientation of the terminal.

*Note: It is the responsibility of the installer to ensure the Horizontal Power Flue Wall Terminal is installed to all relevant building codes to ensure weather tightness.*

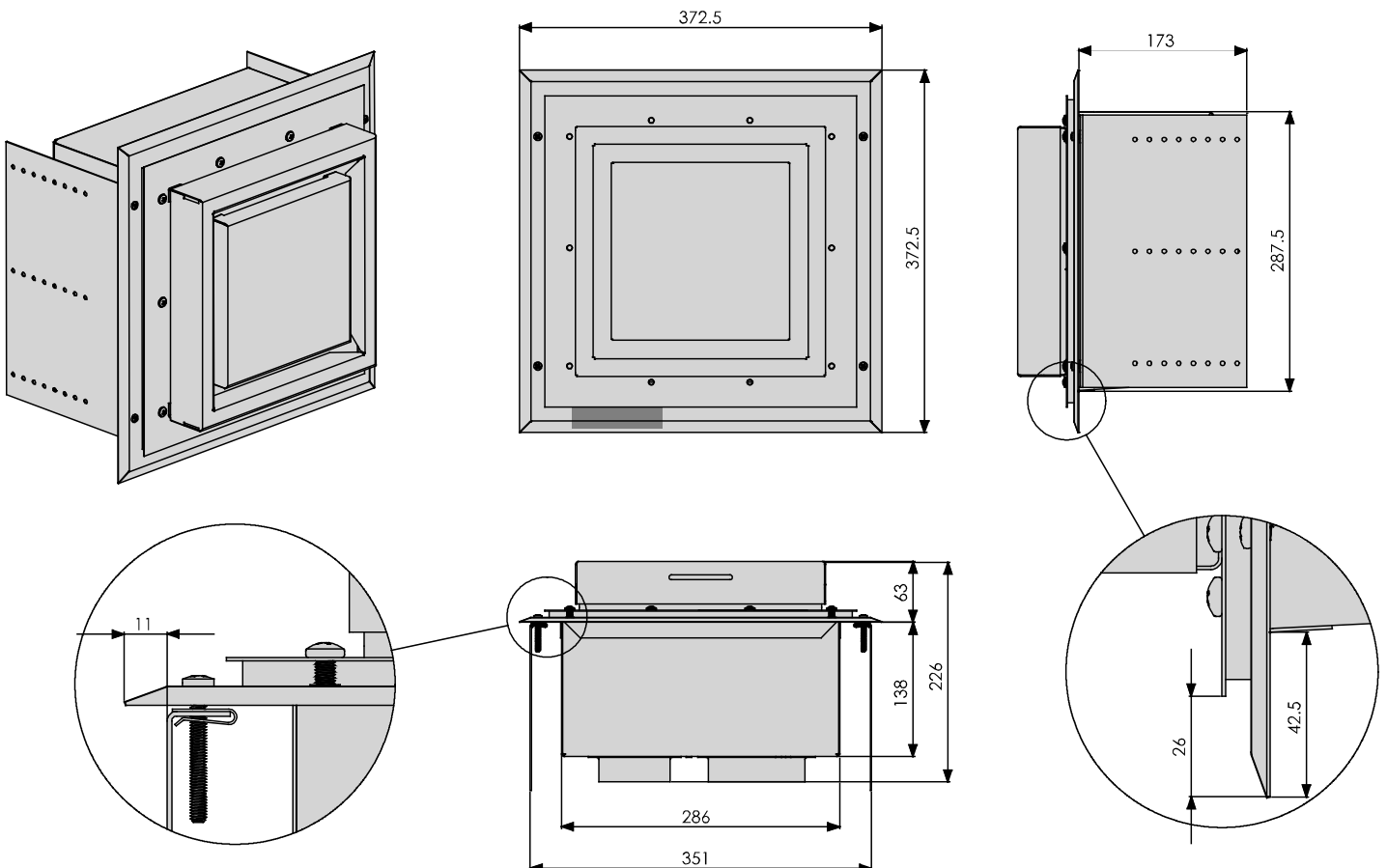
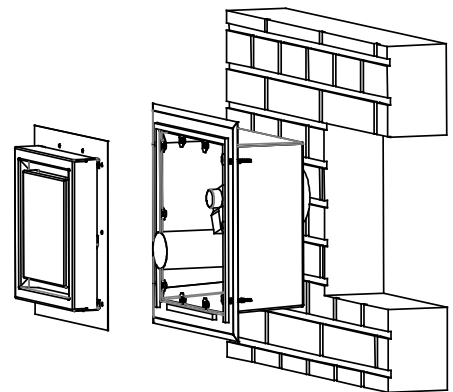

## Creating the Hole in the Outside Wall

When cutting the hole in the outside wall, be mindful of how the installation of the Horizontal Power Flue Wall Terminal will be finished; the installation must be weatherproof.

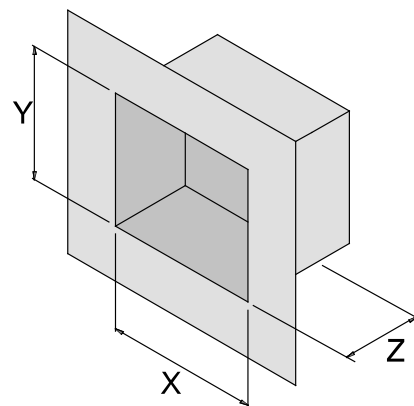

### Ideal hole/cavity size for horizontal Power Flue

	Without Side Brackets	With Side Brackets
X	298mm	360mm
Y	298mm	298mm
Z	175mm Excluding allowance for flue which exits here	

The Horizontal Power Flue Wall Terminal can be attached to the wall in two ways:

A) By attaching the optional wall terminal installation brackets to the sides of the cavity and attaching the Horizontal Power Flue Wall Terminal to these, from the front:

B) From the front of the terminal:

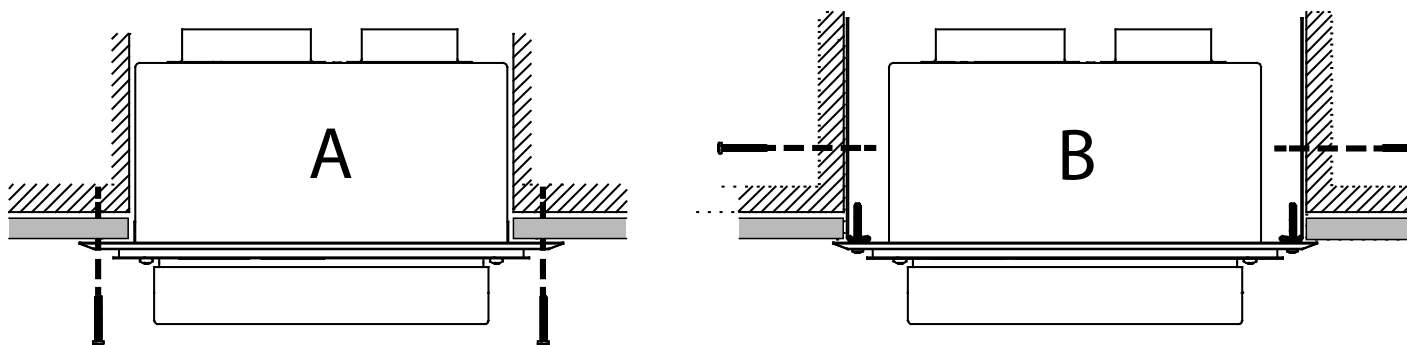

Attach the  $\varnothing 100\text{mm}$  and  $\varnothing 75\text{mm}$  flexible aluminium flues to the spigots on the rear of the Horizontal Power Flue Wall Terminal using the hose band clamps supplied. Plug the Power Flue electrical cable into the back of the Horizontal Power Flue Wall Terminal.

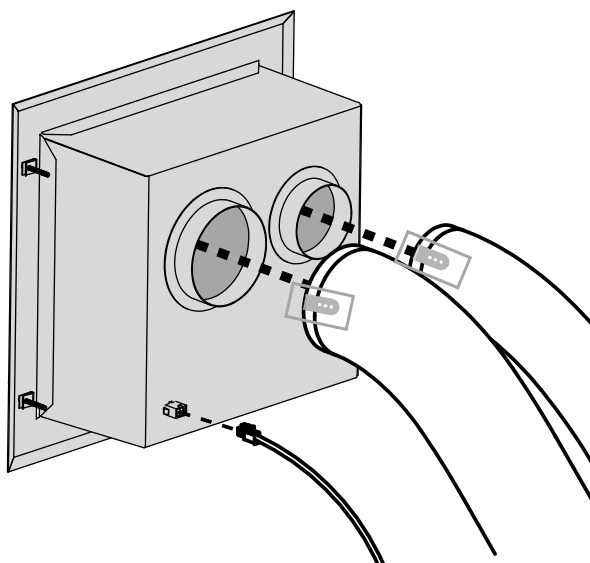

For information on the PolyPro flue, see the installation manual which is supplied with the flue components.

Ensure that the electrical cable is firmly secured to the wall terminal or building to prevent damage or disconnection if pulled.

Fit the Horizontal Power Flue Wall Terminal into the hole and fix it in place, making sure the installation is sealed appropriately to prevent the ingress of water from outside the wall cladding.

*Note: It is the responsibility of the installer to ensure the horizontal Power Flue wall terminal is installed to all relevant building codes to ensure weather tightness. This may necessitate the use of appropriate flashing material where appropriate.*

**IMPORTANT: ENSURE THAT FLASHINGS DO NOT RESTRICT THE AIR INTAKE SLOT AROUND THE PERIPHERY OF THE COWL.**

## How to Flash the Horizontal Power Flue

The following diagrams are excerpts from the Escea architect drawings and are available in full on our website. These diagrams are recommendations, and your installation must comply with any local or national building codes.

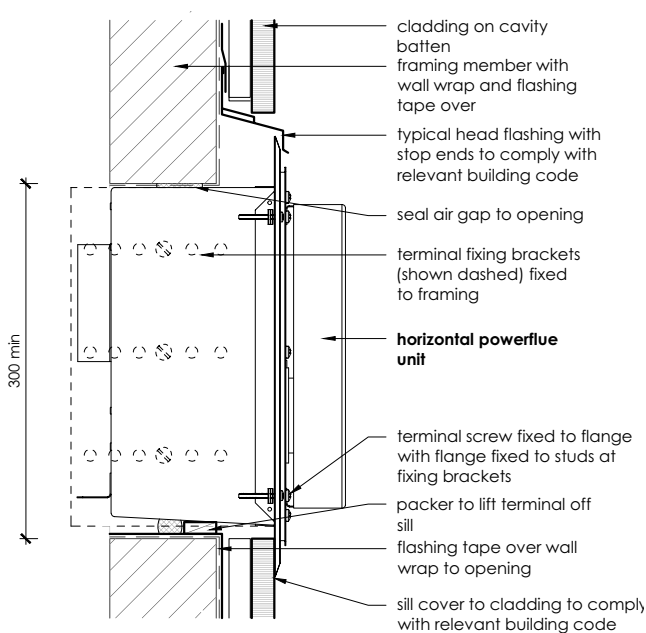

Head and Sill scale 1:5

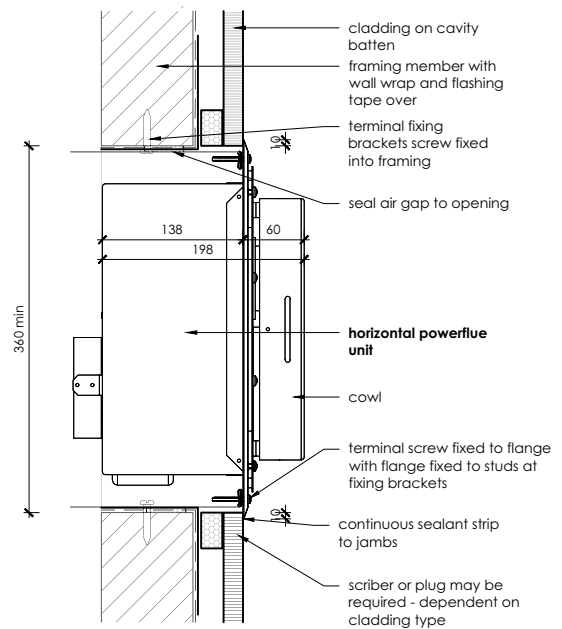

Jamb scale 1:5

## C4 Installing the External Vertical Power Flue (UVP)

The UVP is designed to have the enclosure containing the fan unit mounted externally. Escea recommends this install for a UVP powerflue; an example is shown below.

*Note: When installing the unit onto a flue liner, ensure the length of flue liner above the roof is the minimum required length. ENSURE the  $\text{\O}43\text{mm}$  restriction plate is installed on the inlet.*

The cowl surround should be fixed in place as shown right.

Mount the UVP kit to the top of a chimney flashing plate or penetrate the roof with an optional flue liner accessory and fit the UVP kit over the flue liner, sealing the penetration with a decktite or similar flashing.

Ensure the terminal is vertical and rigidly mounted and the flexi flue attached below is fixed to the terminal spigots using the supplied hose clamps and aid clips.

Place the clamp over the flexi flue and the clip over this. Make sure the flexi tube has been stretched out as far as possible where the hose band clamps are going to be attached (not still compressed). Slide the flexi tube over the spigot and hold it in place by drilling one hole through the spigot using the clip guide hole and riveting the three components together.

*Note: If this install is unpractical for your situation see information regarding an internal install of the UVP, go to section C5 on page 17.*

**NOTE:** The new DF700 and DF960 fires need to be paired with a specific inlet flue restrictor to work as intended, some UVP units will already have this installed, If your powerflue has the smaller restrictor on the inlet (shown bottom left) a replacement restrictor is required, please contact your nearest supplier and request the spare part. If you have the large restrictor (shown bottom right) this is the correct version.

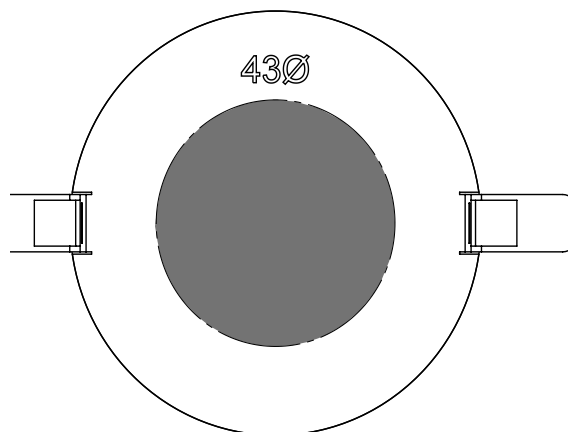
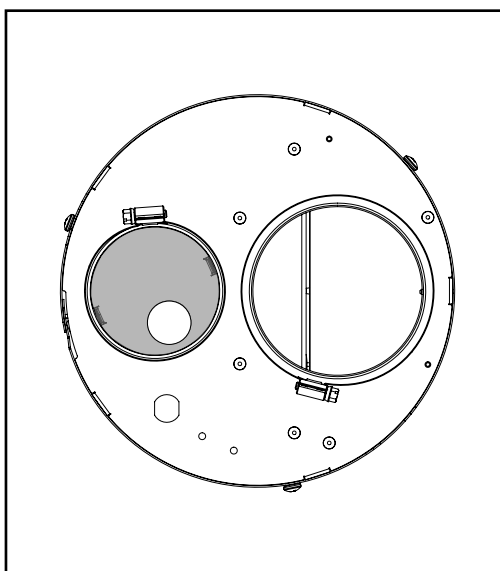
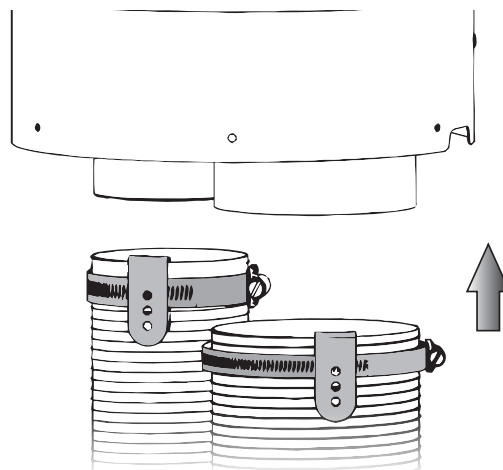
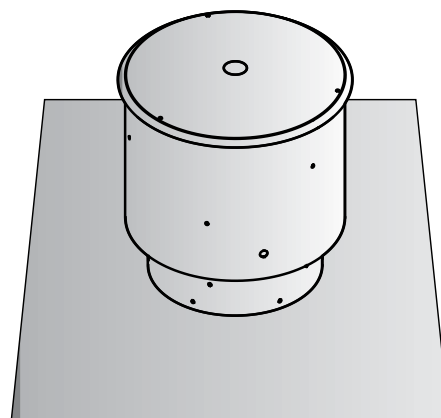

## C5 Installing the Internal Vertical Power Flue

*Note: Internal install is only recommended for situations where an external install is unpractical. For information regarding an external install of the UVP, go to section C4 on page 16.*

The Universal Vertical Power Flue (UVP) internal configuration is designed to have the fan, mounted within the roof space of the house, and the vertical  $\text{\O}225\text{mm}$  diameter liner, containing a  $\text{\O}100\text{mm}$  flexi, penetrate through the roof. The UVP internal conversion kit comes with a 1200mm liner that is specific to the internal installation and must always be used.

*Note: The flue setup must comply with section C1 on page 12 or C2 on page 13*

Use standard methods to flash the roof penetration. The installation must be weatherproof and conform to all local council standards including powered flue termination rules.

Mount the fan mount bracket (1) to the roof framing and strapping using timber ensuring that the flue is rigid and vertical. Ensure that the mounting timber does not obstruct access to the 3xM5 screw threads on the side of the fan unit.

Aim to have the fan enclosure (2) mounted as high as possible, mainly to allow sufficient fall for condensation drainage if the flexi-flue is to run horizontally.

Ensure there is sufficient space below fan enclosure (2) to have access to fit the flexi-flue tubes (3) and allow flowing bends if required.

*NOTE: The new DF700 and DF960 fires need to be paired with a specific inlet flue restrictor to work as intended, some UVP units will already have this installed, if your powerflue has the smaller restrictor on the inlet (shown bottom left) a replacement restrictor is required, please contact your nearest supplier and request the spare part. If you have the large restrictor (shown bottom right) this is the correct version.*

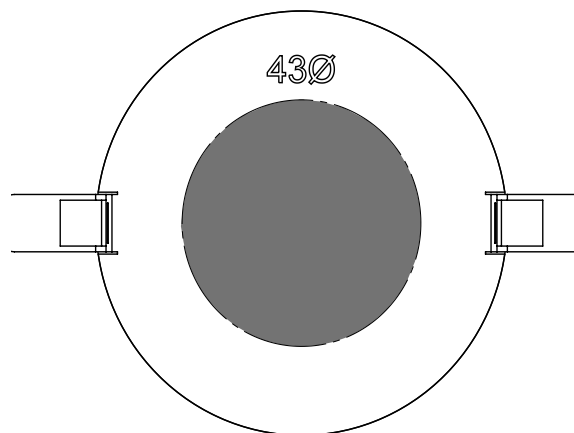
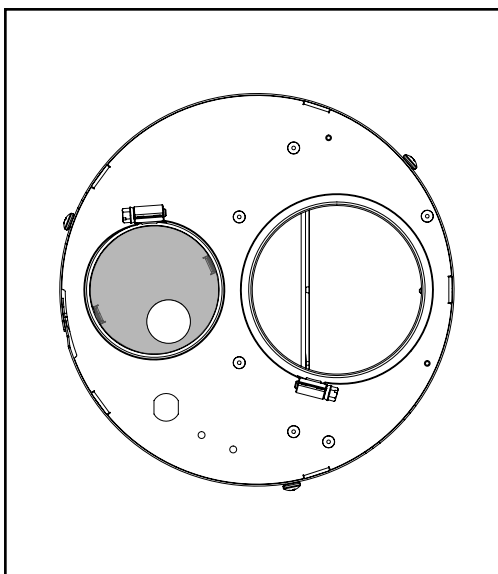
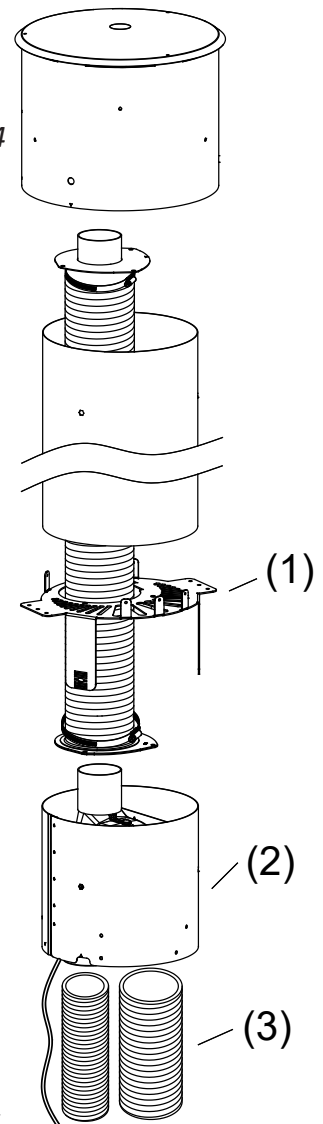

*Note: The UVP-Internal and the flexi flue connections must be installed in a location accessible for service or replacement; a service hatch or removable flashing to allow access is required.*

*Note: When installing the unit onto a flue liner, ensure the length of flue liner above the roof is the minimum required length.*

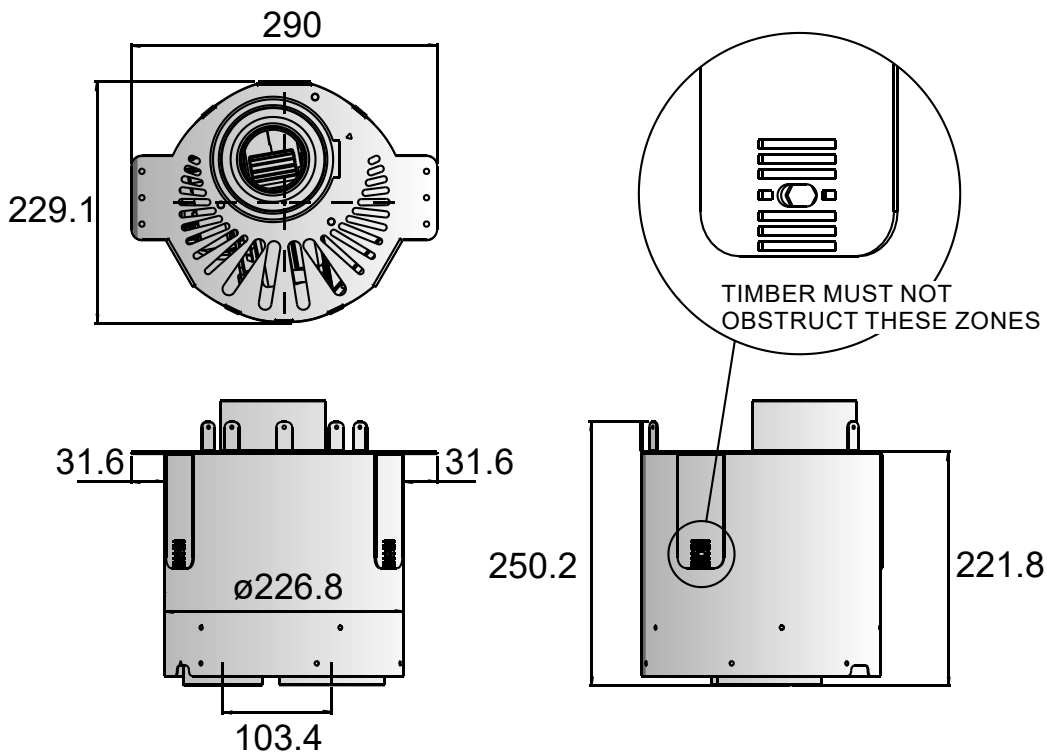

The UVP-Internal kit is intended for use within an accessible roof space.

**SERVICE ACCESS MUST BE PROVIDED.**

Ensure installation complies with relevant building codes and regulations.

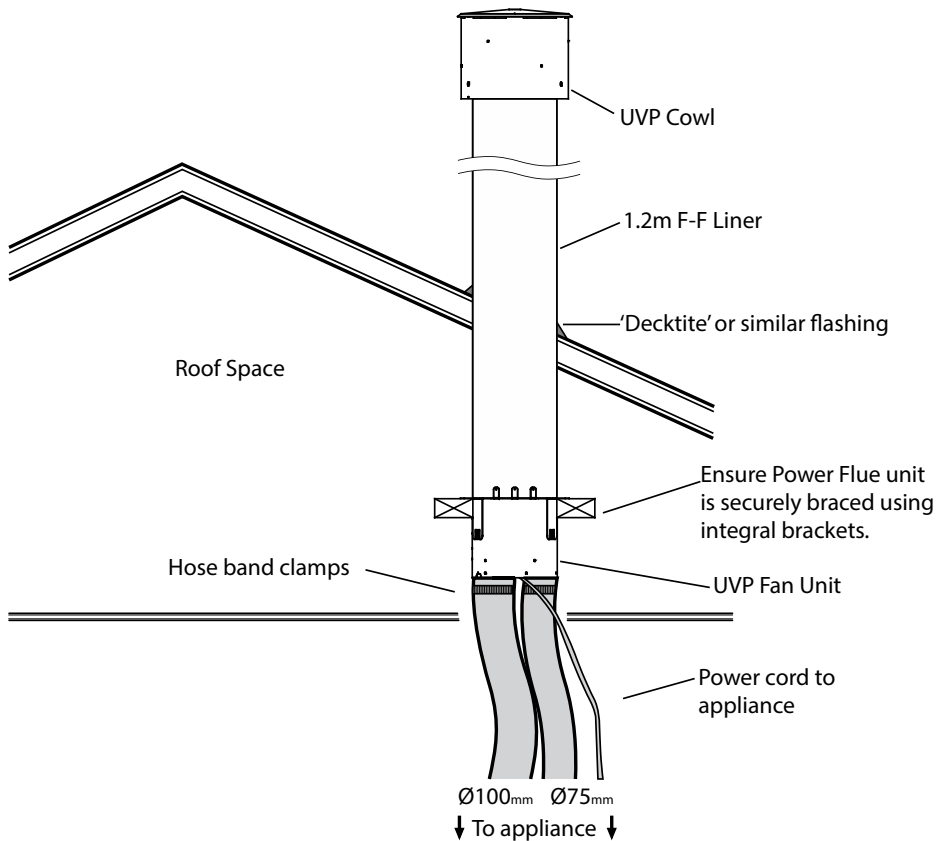

## C6 Installing in Accordance with Relevant Codes

The location of the Horizontal Power Flue Wall Terminal must be installed in accordance with AS/NZS 5601 and any other relevant building codes. If possible, avoid installing the Horizontal Power Flue Wall Terminal in areas exposed to high winds and extreme weather.

Some of the minimum clearances for a fan assisted wall terminal are listed below; please refer to AS/NZS 5601 Gas installation standard for full guidance on the design of the flue system. Where possible allow a greater clearance.

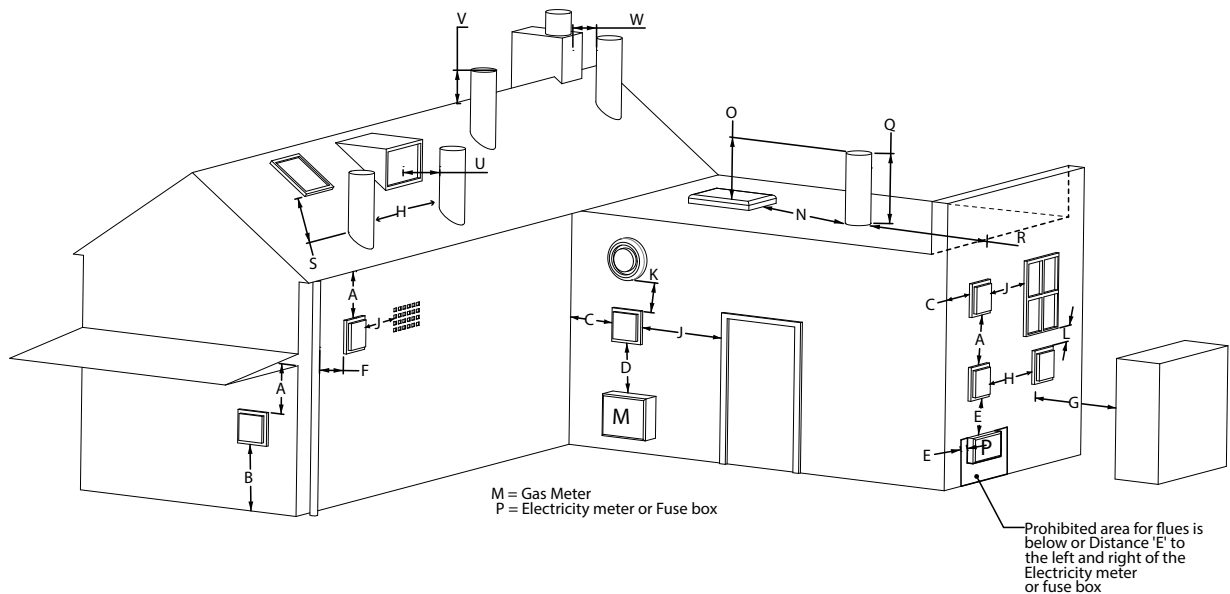

A	Below eaves, balconies and other projections	200mm
B	From the floor, above a balcony or other surface	300mm
C	From a return wall or external corner	300mm
D	From a gas meter or regulator vent	1000mm
E	From electricity meter or fuse box	500mm
F	From a drain pipe or soil stack	75mm
G	Horizontally from any building structure or obstruction	500mm
H	From any other flue terminal or combustion air intake	300mm
J	Horizontally from any openable window, door, non-mechanical air inlet, or any other opening into a building with the exception of sub floor ventilation	300mm
K	From a mechanical air inlet or spa blower	1000mm
L	Vertically below any openable window, door, non-mechanical air inlet, or any other opening into a building with the exception of sub floor ventilation	300mm
N	Horizontally from a roof light	600mm
O	Vertically from a roof light	500mm
Q	Vertically from a flat roof	500mm
R	Horizontally from a vertical structure	500mm
S	Below a roof window	2000mm
T	Above or either side of a roof window	600mm
U	From a dormer window	1500mm
V	Above the apex of the roof (see note 1 on following page)	300mm
W	From an open flue	1500mm

**Notes:**

- Should the flue not extend past the apex of the roof, the bottom opening of the flue should extend at least 200mm from the roof (or 300mm in regions with heavy snow).
- The installation of a flue into a carport is not recommended.
- The flue terminal will get very hot when in use. Precautions should be taken to protect people and animals from injury.
- When installing in an enclosed balcony, follow AS/NZS 5601.1 for appropriate clearances.

**C7 Running the Flue**

Run the  $\varnothing 100\text{mm}$  ID and  $\varnothing 75\text{mm}$  ID ( $\varnothing 110\text{mm}$  OD and  $\varnothing 85\text{mm}$  OD) flexible aluminium hoses from the unit to the rear of where the Horizontal or Vertical Power Flue Terminal will be installed. Allow enough stretch in the flexible aluminium flue to allow it to be able to protrude through the wall/ceiling/roof/flue liner to enable it to be connected to the Power Flue Terminal. The flue should be expanded at each end in order for the flue to be attached to the fire/Power Flue. It is advisable to secure the flexi flue at regular intervals to prevent vibration, movement and sagging. Steel wire or 'builders strapping' may be used for this purpose.

*Note: The flexible flue is shipped in a 'compressed' form. Extend it to your desired length by stretching.*

For information on running the PolyPro flue, see the installation manual which is supplied with the flue components.

**C8 Running the Power Flue Electrical Cable**

*Note: The Power Flue Terminal is powered from the appliance, and must be connected to the appliance with the supplied electrical cable only.*

*Note: Ensure that the appliance power supply is disconnected before making the connection to the terminal.*

The supplied electrical cable is 7m long, flue extension kits also include a Power Flue electrical cable extension.

Run the electrical cable from the unit where the appliance will be installed to the hole in the outside wall. Ensure it is not draped over, or in contact with, the outer shell of the appliance or the exhaust flue and kept clear from any other possible heat sources, sharp edges, or moisture. Fix it appropriately and allow enough cable looped to be able to pull both the appliance and the Horizontal Power Flue Wall Terminal out from their installed positions.

***Push the cable into the fire through the grommet, this will be plugged into the electronics tray in section "E4 Connecting the Power Flue Cable" in the main fire manual.***

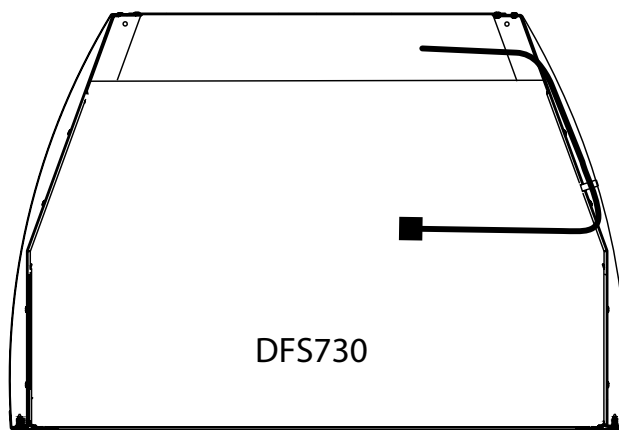
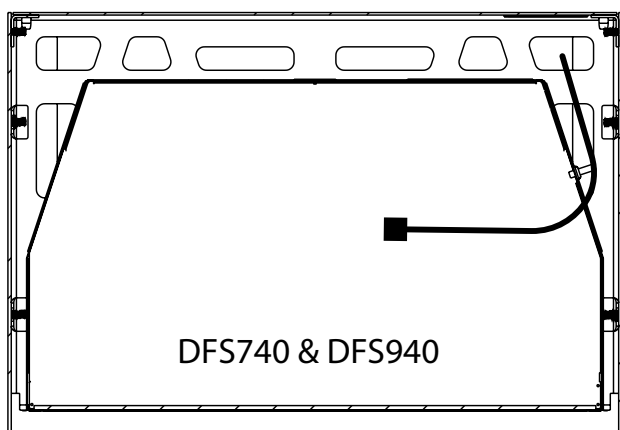

**IF YOU DO NOT CONNECT THE POWER FLUE ELECTRICAL CABLE TO BOTH THE FIREPLACE AND THE POWERFLUE, THIS WILL RESULT IN AN ERROR WHEN THE FIREPLACE IS TURNED ON.**

**TEST THE FAN BEFORE CONTINUING WITH THE REST OF THE INSTALLATION.**

Tie the Power Flue cable onto the  $\varnothing 75\text{mm}$  Air Flexi Flue as shown below. It must be kept away from the  $\varnothing 100\text{mm}$  Exhaust Flexi Flue.

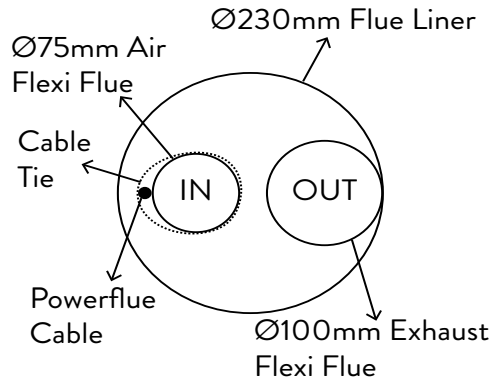

### C9 Setting up the Flue Spigot Plate

Remove the spigot plate from the fire by undoing the tension bolt and connect the flexi flue to the spigot plate through the flue liner using the hose band clamps provided while the unit is still empty.

**DO NOT OVER STRETCH THE ALUMINIUM FLEXI FLUE.**

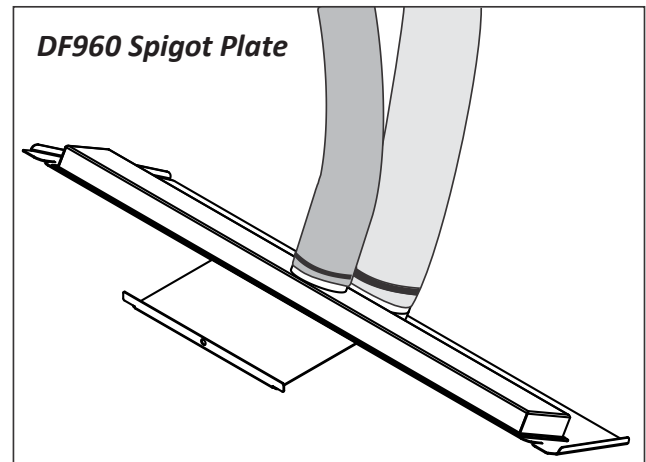
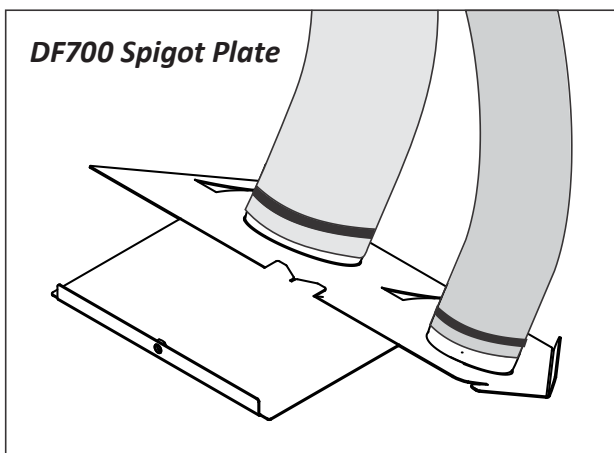

# D INSTALLING THE ELECTRICITY AND GAS TO THE APPLIANCE

In order to install gas to the fireplace, check the operating pressure or install the network cable, the glass and burner tray needs to be removed.

## D1 Power Supply

While the unit is being situated, consideration must be given to the location of an appropriate power supply. An earthed 230/240 volt mains power connection (typically a standard 3 pin outlet) must be available within 1m of the rear right of the unit. This connection must be accessible after the heater has been fully installed so that the appliance can be safely disconnected from the mains power supply prior to servicing.

A mains isolation switch (compliant to AS:NZS 5601 Clause 6.2.8) which is accessible from outside the unit can also be used to disconnect the power.

Regardless of the method used, it **MUST ALWAYS** be possible to safely isolate the electrical supply to the appliance after it has been fully installed.

This appliance must not be located immediately below a socket outlet. This appliance will draw a maximum of 2 Amps from a 230/240V supply. No additional power supply is required for the Power Flue.

An electrical wiring diagram is located underneath the electronic tray, and also in the rear of Service Section S13 in the main fire manual.

## D2 Removing the Glass

The DF-Series fireplace has two layers of glass: the inner glass seals the firebox and is called the primary glass; the outer glass is called the secondary glass.

### Secondary Glass

1. Unscrew the secondary glass retainers and slide them towards the middle of the fire.
2. Tilt the glass toward you slightly, lift the glass out of the bottom glass retainer and carefully set glass aside.

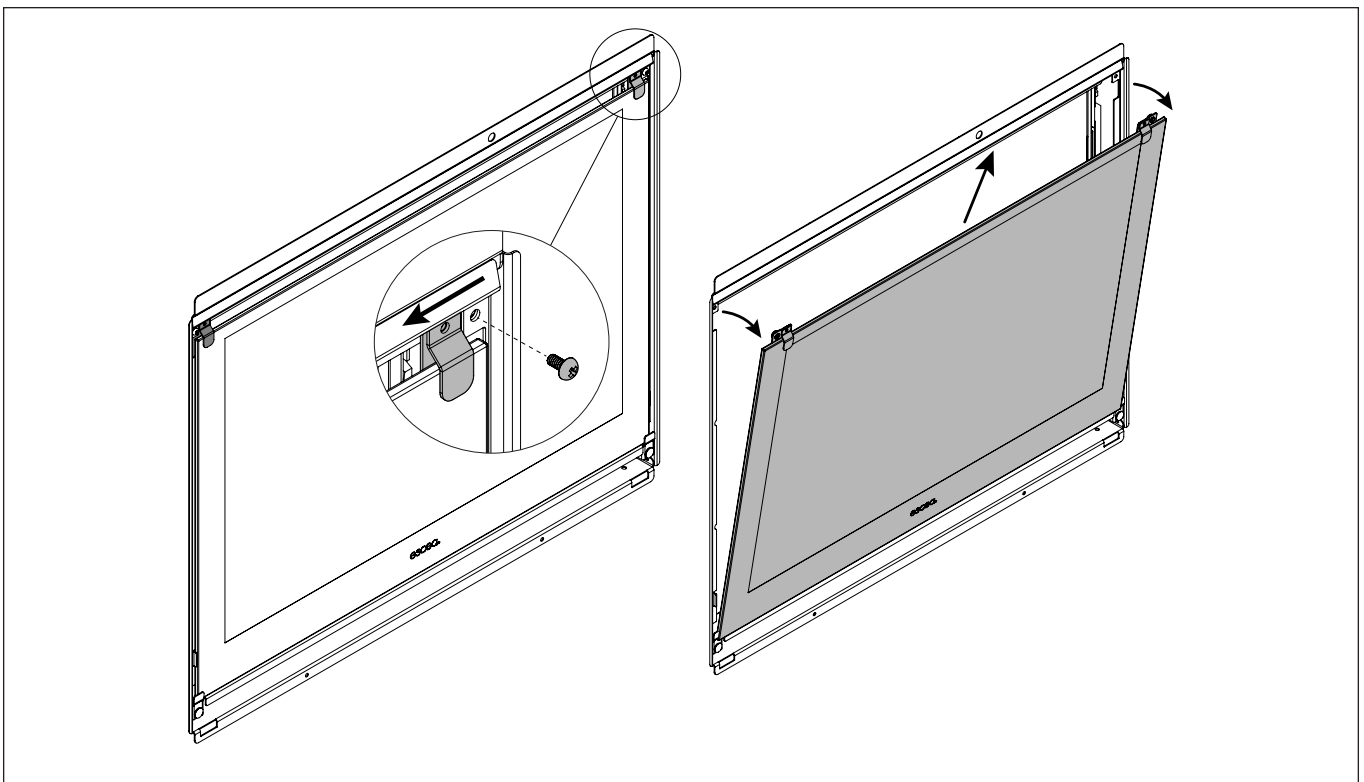

## Primary Glass

- Remove the two screws holding in the top of the primary glass, then pull forward, tilt down and then slide out the glass retainer through the gap in the side flanges.

*NOTE: Please slide the top trim ramp forward with caution to avoid scratches to the finish as the front of the part is visible.*

- Remove the bottom trim by tilting back and pulling out the gaps in the chassis.
- Partially undo the four screws holding in the side retainers, then slid up and twist out leaving the screws behind.
- Pull the top of the glass toward you slightly, lift the glass out of the bottom glass retainer and carefully set glass aside. Note that the fiberglass tape around the glass can mark carpet and furnishings - use a drop cloth to protect furniture.

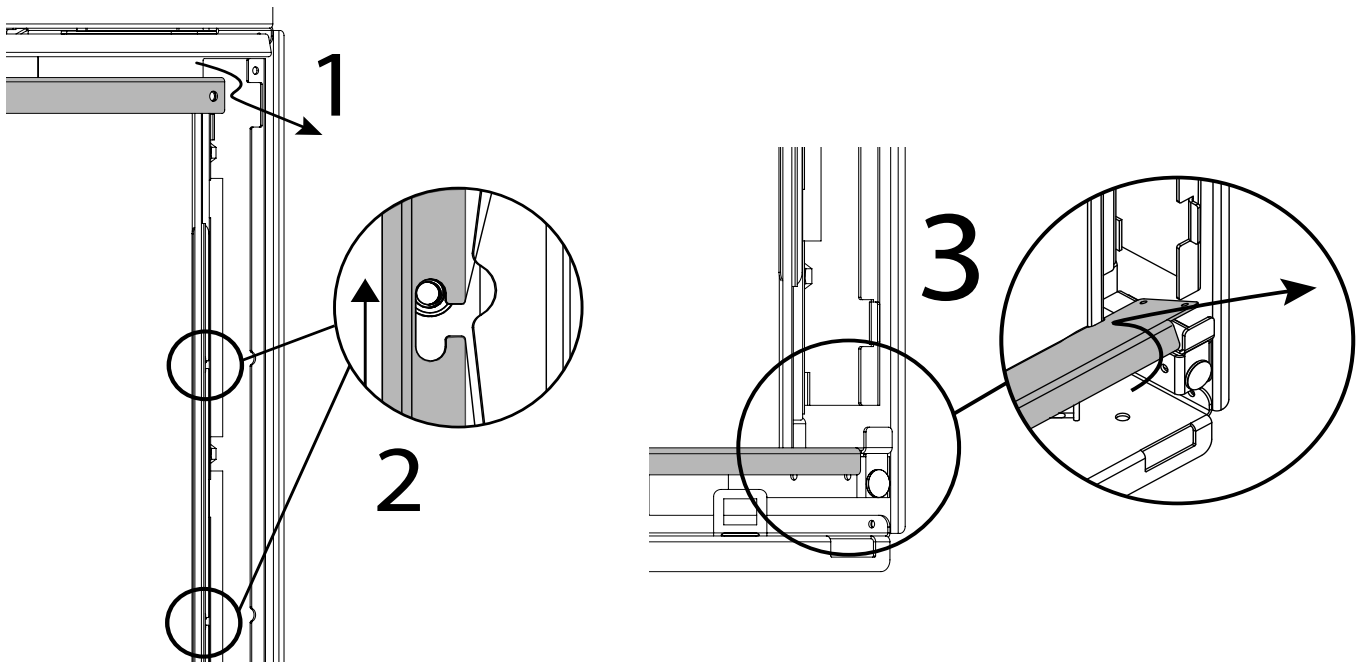

## D3 Removing the Burners

Remove the 2 screws in the rear corners of the infill assembly and the 2 screws either side of the pilot guard (shown in diagram below). Lift the infill assembly up and out of the firebox; place it carefully aside.

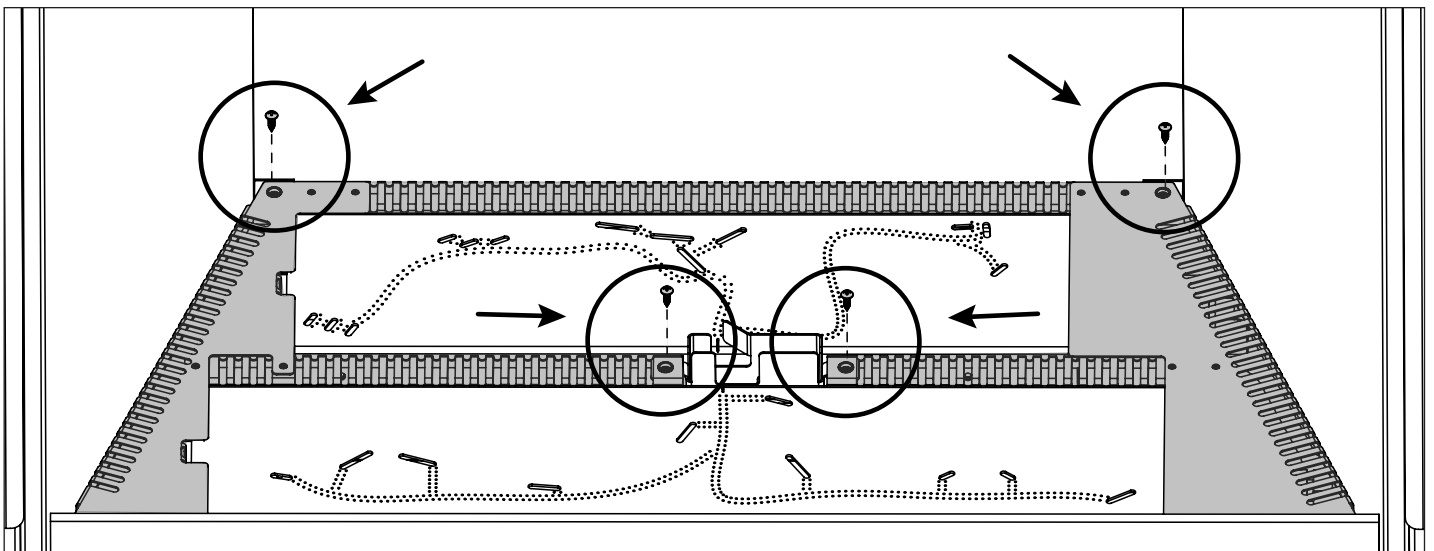

Carefully move the burner left to detach the burner tube from the burner jets and lift out of the firebox.

## D4 Gas Pipe Sizing

Gas pipe should be sized as per the requirements of AS/NZS 5601. The pipe sizing must be sufficient to deliver the following volume of gas to the heater with all other gas appliances in the home running at the same time:

**DFS730 & DSF740 GAS CONSUMPTION = 23MJ/HR**

**DFS940 GAS CONSUMPTION = 31MJ/HR**

## D5 Gas Pipe Position

The DF-Series fireplace gas pipe entry point for the DFS units is located in the right hand of the chassis base; a corresponding hole in the freestanding unit (circled below) allows direct access to the regulator. Attaching the pipe will come in section "E7 Connecting the Gas Pipe to the Regulator" in the main fire manual.

### DFS730

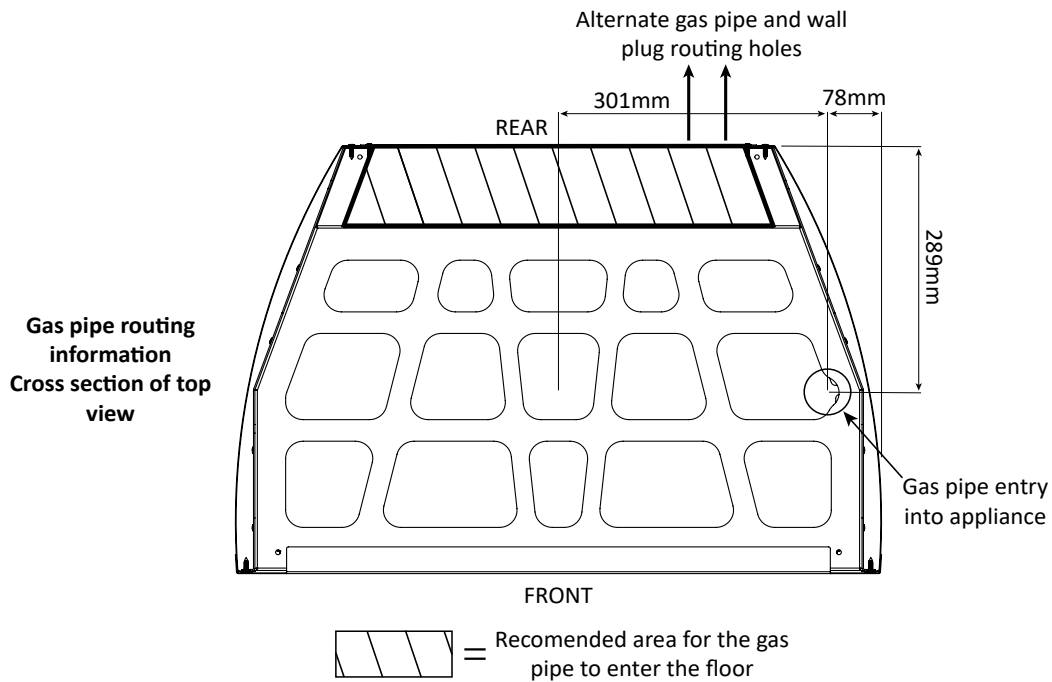

### DFS740 & DFS940

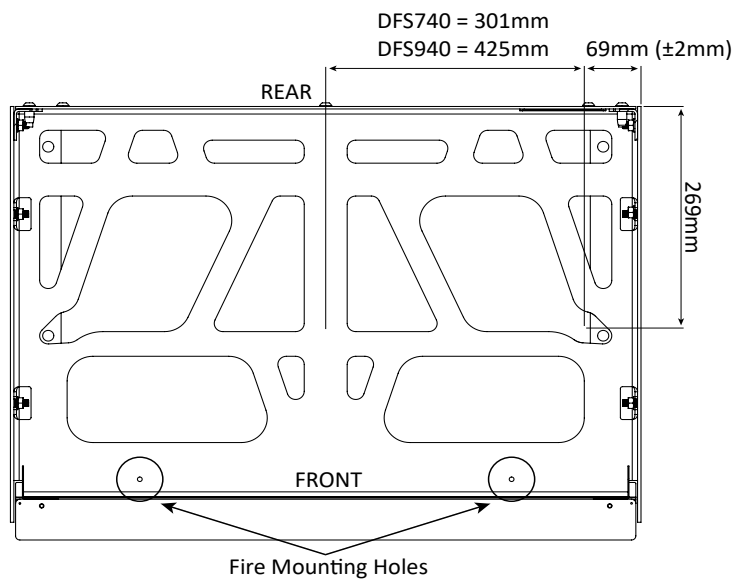

## D6 Gas Supply

Escea does not condone using a 9kg bottle as the main gas supply for an Escea fire. Doing so could result in a dirty or poor flame and produce excess soot build up.

# E INSTALLING THE APPLIANCE

## E1 Securing the Unit

Escea recommends securing the Freestanding units down to the floor using the four holes located in the bottom of the units.

The DFS730 fixing holes are easily accessible from the inside of the unit.

The DFS740 and DFS940 fixing holes are in tighter locations and as such the dimensions are shown below.

### DFS740 and DFS940 Unit Fixing Hole Locations

*NOTE: The fixing holes are 13mm, escea recommends using M8 fixings with a washer.*

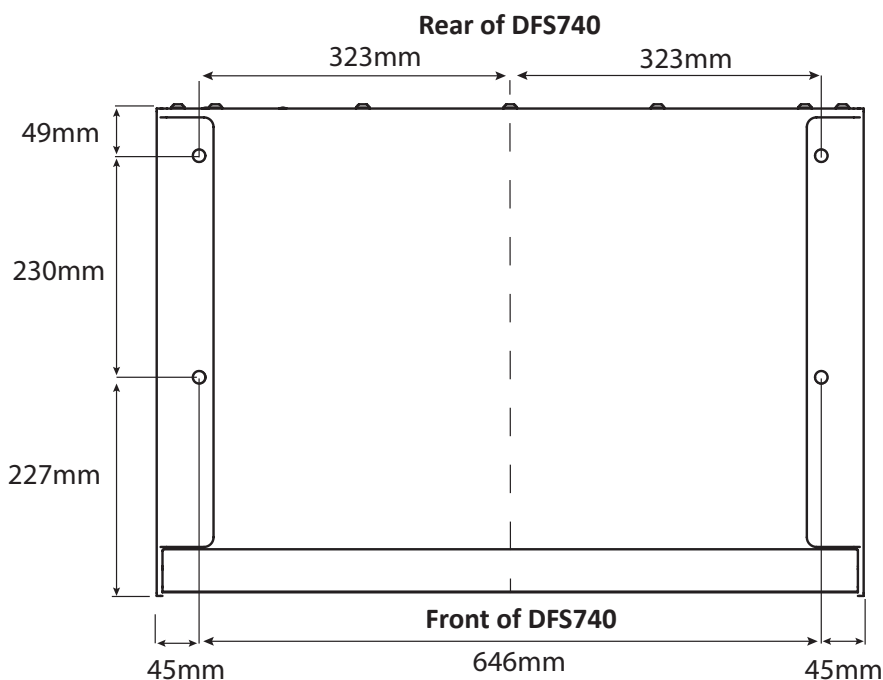
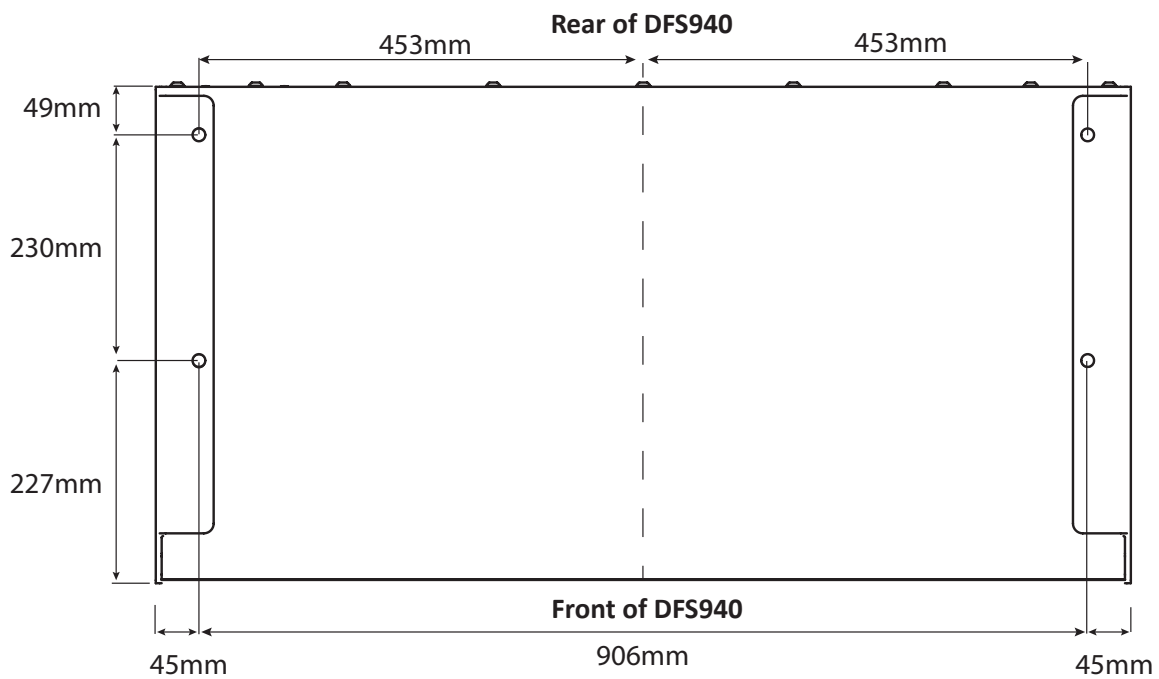

## E2 Routing the PowerFlue and Power Cable

Carefully push the fireplace into the unit just enough to bring the powerflue cable through the silicone grommet of the appliance shown in the diagram below. This will be plugged in later in the process.

The power cable and home automation cabling can be run either

- Out the back of the unit which can be done while sliding the fire in or
- Down into the floor in the rear section of the unit

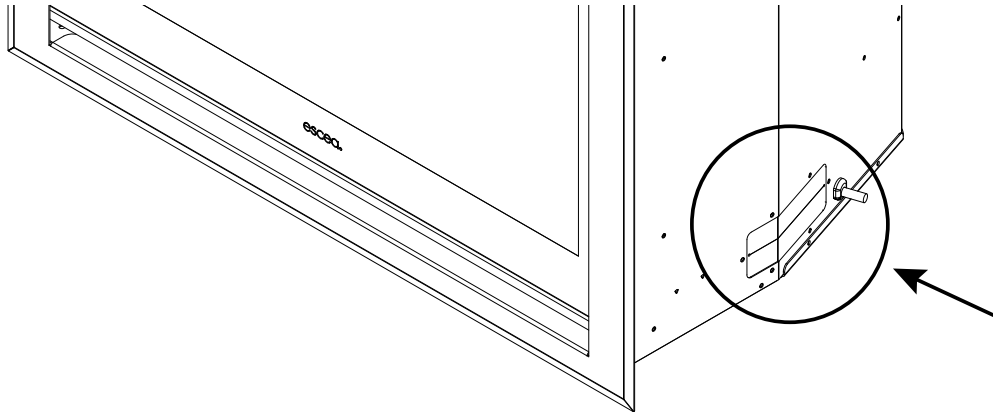

## E3 Connecting the Flue

The appliance should have enough room above the fireplace to reach in and align the flue spigot plate onto the rails (highlighted in the diagram below). Use the long M5 screw to pull in the spigot plate as the fire is pushed into the unit.

*Note: The DFS730 lid can be removed to ease this part of the installation. This does not apply to the DFS740 and 940.*

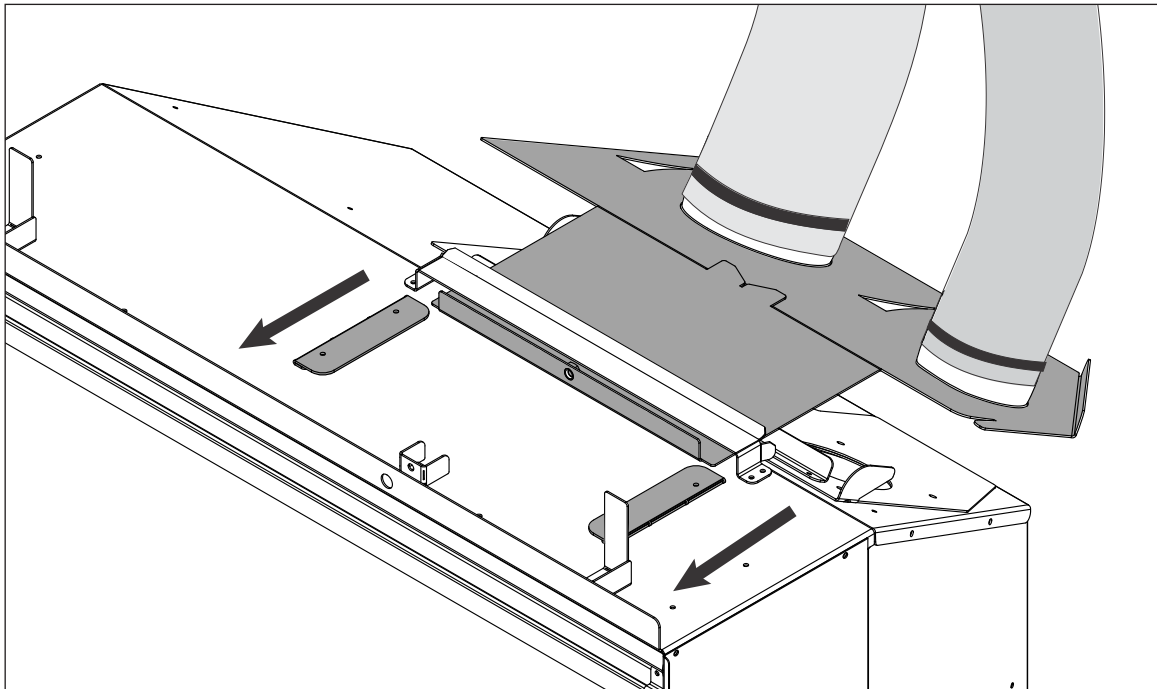

Make sure that all of the fold up tabs (circled in the diagram below) used for locating the flue spigot plate onto the chassis are poking through the flue spigot plate.

*Note DF960 has 6 tabs.*

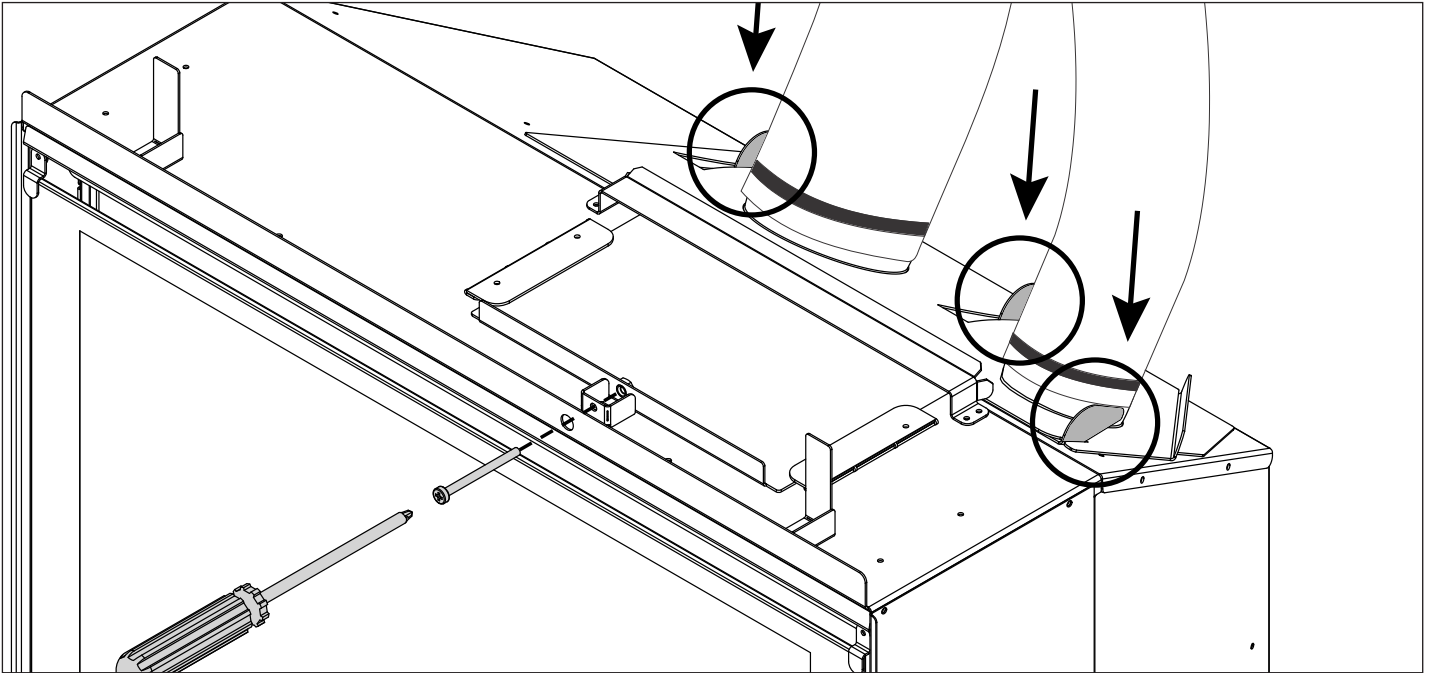

Insert the 1 long machine screw into the location shown in the diagram above to secure the flue spigot plate to the chassis

## E4 Move to the Main Manual

Move to the main DF700 & 960 Installation manual that comes with your fire to complete steps E3 to E14 and Section F, finishing the installation using the below Fascia Alignment Guide to install the Fascia.

## E5 Fascia Alignment Guide

1. First line up the two prongs of the fascia with the notches in the fire as circled below.
2. Push the fascia on being careful to not scratch the sides of the unit.
3. DFS730 only - Screw in the two screws on either side of the fascia under the lip of the lid.

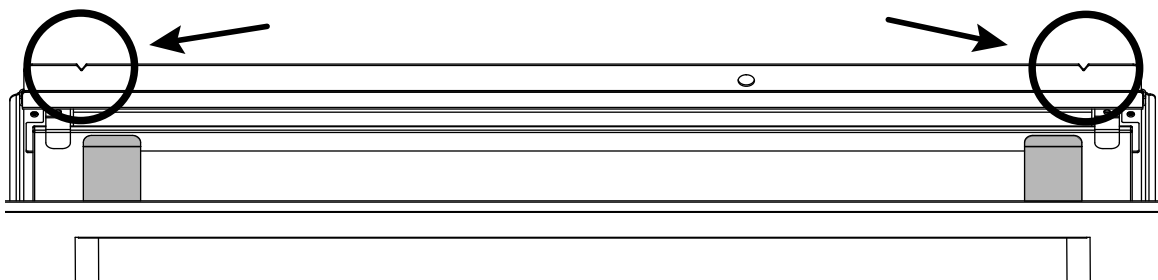

# F INSTALLATION CHECKLIST

---

Go through the following checklist to ensure you have installed the appliance correctly

- Correctly situated freestanding unit to suit your flue configuration**
- Correct clearances to combustibles around the freestanding console**
- An electrical isolating switch to the appliance, accessible after finished installation**
- Correctly sized gas supply with a pressure test point, ensuring adequate supply with all other gas appliances in the dwelling running**
- A weather-tight installed Horizontal or Vertical Flue Terminal with clearance as specified by AS/NZ5601**
- Power flue cable connected correctly to the Power Flue Terminal and the electronics tray within the appliance**
- Reasonable access to the Horizontal or Vertical Flue Terminal for maintenance purposes**
- Flue attached to the rear/bottom of the flue terminal leading back to the appliance**
- The appliance fixed to the freestanding console base**
- The appliance plugged into a mains electricity supply**
- All gas joints and pressure points leak tested, and soapy water and drop tests completed on gas pipework**
- Gas type conversion process carried out if required**
- Log or coal fuel bed correctly installed**
- Primary and secondary glass correctly fitted**
- A fitted fascia**
- The remote control mounted on its cradle on a wall**
- Operated the fire and verified that it lights reliably and safely**
- Run the appliance on full for an hour with the doors & windows open**
- Appliance functions checked, including thermostat operation, Flame Effect and Fan Boost**
- Home-owner shown how to operate the appliance correctly**
- User Guide made available for end user**
- Plumbing Industry Commission Compliance Certificate given to end user**