



**The Warmest Aussie Legend**

## **COONARA “HERMITAGE”**

### **HIGH EFFICIENCY GAS LOG SPACE HEATER**



**CONSOLE MODEL**



**INBUILT MODEL**

# **CUSTOMER OPERATING INFORMATION & INSTALLATION INSTRUCTIONS**

Serial Number of Heater: \_\_\_\_\_ Model: \_\_\_\_\_

***Hermitage Gas Heaters*** ARE AUSTRALIAN OWNED & MANUFACTURED BY

**SHAMIC SHEETMETAL** (AUST.) PTY. LTD.

PO BOX 8, KILSYTH, VIC. 3136 PH: 03 9737 5300

<https://www.coonara.com>

## **WARNING**

**THE FOLLOWING INSTRUCTIONS MUST BE CARRIED OUT OR WARRANTY MAY BECOME VOID.**

**Heater must be installed by an authorised person. You must obtain a license number from the installer.**

**Heater must be placed on a flat level surface. Inbuilt models must be placed on 6mm AC sheeting, to prevent unit from rattling.**

**Heater must be checked for scratches or dents prior to installation.**

**All glass must be fitted with a screw driver not a drill. If glass is broken upon installation due to the screws being over tightened, it will not be classed under warranty.**

**Further safety precautions and installation instructions are contained throughout this manual.**

**Please read the manual before installation.**

# CONTENTS

PRODUCT FEATURES _____	<b>4</b>
CUSTOMER OPERATING INSTRUCTIONS _____ SAFETY PRECAUTIONS	<b>6</b>
SAFETY FEATURES _____	<b>7</b>
INSTALLATION INSTRUCTIONS _____	<b>8-14</b>
LOG INSTALLATION & WIRING DIAGRAM _____	<b>15</b>
GAS VALVE ADJUSTMENT _____	<b>16</b>
TROUBLESHOOTING GUIDE _____	<b>17</b>
DIMENSIONS & WARRANTY _____	<b>18-19</b>
CARE OF APPLIANCE _____	<b>20</b>
SERVICE CONTACT & WARRANTY INFORMATION _____	<b>21</b>

# PRODUCT FEATURES

MODEL-Hermitage, Chateau, Mystique			Manufacturer
<b>GAS TYPE</b>	NATURAL	L.P.G	
MODEL TYPE	Freestanding Inbuilt	Freestanding Inbuilt	Shamic Sheetmetal (Aust.) Pty.Ltd.
GAS INPUT HIGH LOW	33 MJ/h 23 MJ/h	33 MJ/h 23 MJ/h	<b>PO BOX 8, KILSYTH, VIC. 3136</b>
HEAT OUTPUT HIGH LOW Efficiency Injector Size Manifold Pressure High Low A.G.A Approval No. to Code AS/NZS 5263.1.3	7.6 kW 5.2 kW 78.1 % 2.8 mm 0.9 kPa 0.48 kPa AGA 6165 G	7.6 kW 5.2 kW 78.1 % 1.7 mm 2.5 kPa 1.3 kPa AGA 6165 G	To be installed by an authorized person in accordance with installation instructions provided with the appliance.
Electrical Conform to AS3100		240V 50 Hz 120 Watts Max	
Air Pressure Switch		Aria 380 series (5471)	
<b>Cut in Pressure</b>		<b>45 Pa</b>	
<b>Cut out Pressure</b>		<b>40 Pa</b>	
<b>Electrical Connection</b>		<b>Standard Flex. 2 Mt. 3 Pin Plug</b>	

Hermitage Freestanding and Inbuilt gas log heaters.

- 33 Mj/h Gas Input Natural Gas and LPG.
- 7.6 kW Output.
- Energy rating **4.6** stars
- Electronic ignition.
- Two heat settings.
- External combustion air intake - prevents de-oxygenation of room air.
- Delayed start room fan - prevents cold air being circulated at start-up.
- Delayed stop room fan - aids cool down of unit when switched off.
- Power flue – Zero Clearance
- Integrated safety features.

The Coonara “Hermitage” Freestanding and Inbuilt models are approved by the Australian Gas Association to Australian Standard AS/NZS 5263.1.3/Gas space heating appliances.

AGA Approval No. 6165 G

This appliance shall only be installed in accordance with:

- AS/NZS 5601 (Gas Installation Standard),
- Manufacturer's Installation Instructions,
  - Local Gas Fitting Regulations,
  - Municipal Building Codes.

This appliance **must** only be installed and serviced by an authorised person.

Please store this manual in a safe place for future reference.

# CUSTOMER OPERATING INSTRUCTIONS

The Coonara “Hermitage”, Gas Log Space Heater has been designed for simple efficient operation, with only two switches for ignition and both High And Low settings.

## PRE-OPERATION CHECKS

Prior to operating the heater, ensure that the flue terminal is not obstructed. Furthermore, make sure there are no combustible objects leaning against, resting on, or within the immediate vicinity of the unit. Check that the heater main power and gas supply are connected and switched on.

## OPERATING THE HEATER

The manual controls for the freestanding model are located at the top right hand side of the appliance toward the rear. Manual controls for the inbuilt model are located on the top front right hand fascia.

To operate the heater, press the smaller of the two switches labeled On/Off to the “On” position, the electronic control will commence a safety check period of approximately 8 seconds prior to igniting the heater. The room fan will start operating once the appliance has begun to heat-up, thus preventing cold air circulation.

To operate on High fire/High fan mode, set the larger switch to the “High” position. When the area to be heated has reached a comfortable temperature level set the switch to the “Low” position.

The heater may be switched on or off, in either the High or Low settings.

**To operate the heater using the optional Thermostat please refer to the “8000 Series Thermostat User Manual” for further information.**

*Note:* At start up, if the “High” position has been selected the heater will only ignite on the “Low” setting and will automatically switch to the “High” setting after an initial warm up period.

## TURNING THE APPLIANCE OFF

Set the smaller of the two switches to the “Off” position.

The room fan will continue to operate for a short period while the heater cools down.

**To turn the heater off using the optional Thermostat please refer to the “8000 Series Thermostat User Manual” for further information.**

**Note 1:** This appliance cannot be operated without the fan operating.

**Note 2:** Due to the performance and efficiency of the heater, steam may be noticed coming from the flue terminal on days of low temperature.

**Note 3:** As this appliance has a luminous flame effect some slight carbon depositions may occur.

**Note 4:** During first time firing of this appliance, an odour may be noticed for a short period as the paint cures. It is advisable to leave a window open during the first few hours of the very first operation only.

## SAFETY PRECAUTIONS

### IMPORTANT POINTS

- ! **DO NOT** place articles or clothing on or against this appliance.
- ! **DO NOT** use or store flammable materials near this heater.
- ! **DO NOT** place any item containing liquid on the heater.
- ! **DO NOT** spray aerosols in the vicinity of this appliance when it is in operation.
- ! **DO NOT** modify this appliance.
- ! **ALWAYS** supervise young children near the appliance.

It is recommended that a secondary guard be used, to prevent access to appliance by children, as outer panels of this appliance may reach high temperatures.

*Note:* In the event that the electricity supply cord is damaged it must be replaced with Coonara part # 6306, obtainable from authorised gas retailers.

## PRIMARY GUARD

A primary guard is fitted to this appliance to reduce the risk of fire or injury from burns and no part of it should be removed. For protection of young children or the infirm, a secondary guard is required.

## SAFETY FEATURES

**Automatic Shut-Off:** Should the flame extinguish for any reason, there is an automatic close off of the gas supply.

Note: fans will continue to operate as normal.

**Over Temperature Protection:** In the event of the room fan failing, blockage of airways, or incorrect gas installation, the gas supply will be automatically closed off to prevent the appliance over-heating.

Record the following information in the space provided.

Purchased from:

Name \_\_\_\_\_

Address \_\_\_\_\_

Phone No \_\_\_\_\_ Date of purchase \_\_\_\_\_

Serial No of Appliance \_\_\_\_\_

To be completed by installer:

Name \_\_\_\_\_ License No \_\_\_\_\_

Address \_\_\_\_\_

Phone No \_\_\_\_\_ Date installed \_\_\_\_\_

**Note: This appliance can only be installed by an authorized person who is responsible for its correct operation at the time of installation.**

### AS/NZS 5601 Appliance Commissioning

9.2 The commissioning of an appliance shall take full account of special design features, the manufacturer's instructions and the appliance safety requirements.

9.3 The commissioning of an appliance shall include all of the following

- (a) Compliance with clauses 2.4.2 and 2.6
- (b) The appliance is to be checked to ensure safe working order.
- (c) The burner of the appliance is to be lit and where necessary adjusted, in accordance with the manufacturers instructions
- (d) The consumer, where available, is to be instructed on the safe and correct operation of the appliance and any auxiliary equipment.
- (e) The appliance operating instructions are to be handed to the consumer, or if the consumer is not present, the instructions are to be left in a suitable location on the premises.

## WARNING

**Heater must be checked for scratches or dents prior to installation.**

**Once the Heater is installed scratches or dents are not covered by warranty.**

**INSTALLATION – Must be placed on a flat level surface to prevent rattles.**

### Freestanding Model

**Note: Not intended for fireplace insert.**

**Only to be carried out by an authorised person!**

Note: Prior to final positioning of the heater consider the location that the flue will penetrate the wall / ceiling to avoid contact with combustible fixtures such as; roof trusses, wall framework, etc. Furthermore, a minimum distance of 1 metre should be maintained between the front of the appliance and flammable objects such as curtains, furniture, etc. Also consider minimum distances to combustible surfaces (ref page 14).

- A. Carefully remove the carton from the heater, remove heater from pallet,
- B. Position the heater where desired,
- C. Remove the 2 screws holding the fascia assembly to the lower cover panel, the fascia is secured to the heater body by 4 lugs and can be removed by lifting the fascia upward approximately 5mm and then forward,
- D. **Check!** The label at the rear of the fire box to confirm gas type is appropriate for the gas supply available,
- E. Remove the lower cover panel by first rotating the top of the panel toward you, and then lifting up and away from appliance,
- F. Loosen the lower glass retaining bracket screws and completely remove the top bracket, remove the glass.
- G. Carefully unpack the logs from their separate carton and position them back into the firebox (refer diagram page 15),
- H. Install flue (see following section),
- I. Connect the gas supply, purge gas line, check all connections for leaks, then check pressures (refer to pressure settings on page 16) and adjust if necessary.
- J. Reassemble heater in reverse order of above, connect electrical cord to correctly wired and earthed 240 volt AC power point,
- K. Operate heater, check operation of heater on both High and Low, ensure fan operates after initial warm up period (refer trouble shooting guide page 17 should any problems occur).

**Note: This appliance will not operate if a power point, power board or extension lead has reverse polarity.**

Instruct customer of correct operating procedure.

## FLUE INSTALLATION

### Vertical Flue Installation

1. Cut a hole 205mm diameter in the ceiling at the desired location, cut a hole of sufficient size for 6" (152mm) outer flue case to pass through roofing material in line with hole in ceiling,
2. Run a plumb line from the centre of hole in ceiling to the flue outlet of the heater (this will ensure flue will run true vertically),
3. Attach the ceiling ring supplied with the flue kit to the ceiling centrally over hole in ceiling,
4. Fit tapered flue dress trim (wide end toward heater) over flue outlet in top of heater,
5. Fit flue inner & outer flue lengths to spigots on top of heater until desired length through roof is achieved.
6. Use a suitable sealant at each end of inner flue – High temperature silicon sealant  
Note: Crimped ends must point upwards on both inner & outer flues.
7. Cut outer flue casing to ensure inner Flue (exhaust pipe) protrudes 50 mm above outer casing!
8. Suitably flash outer flue at roof penetration,
9. Fit cowl to end of flue ensuring both inner and outer flanges cover respective casings adjust length of inner flue by cutting or extending as required. Use sealant on inner flange joint.



## 90 Degree Wall Penetration Flue Installation

1. Determine the exact location for the heater
  2. Attach the outer 900 mm flue and 90 degree bend to the heater
  3. Mark the exact location for the wall penetration
    - Determine that you will not be cutting through any vertical wall studs.
    - Check that the location of the wall-mounted terminal conforms to the requirements of AS/NZS 5601 – Location of a Flue Terminal.
  4. Cut a hole 205 mm in diameter through the wall.
  5. Attach the internal wall plate centrally over the hole.
  6. Fit the tapered flue dress trim (wide end towards the heater) over the flue outlet on top of the heater
  7. Fit the inner and outer 900mm flue lengths to spigots on top of the heater
  8. Fit the 525mm inner and 450mm outer flues through the wall plate.
  9. Fit the inner and outer 90 degree bends to the 900mm lengths.
  10. Fit the short inner and outer lengths to the 90 degree bends.
  11. Trim the inner flue to 50mm longer than the outer flue.
- NOTE.- It may be necessary to trim the outer flue depending on wall thickness.
12. Attach the cowl backing plate to the wall. Seal with silicon sealant.
  13. Fit the wall cowl to the flues and attach to the backing plate.

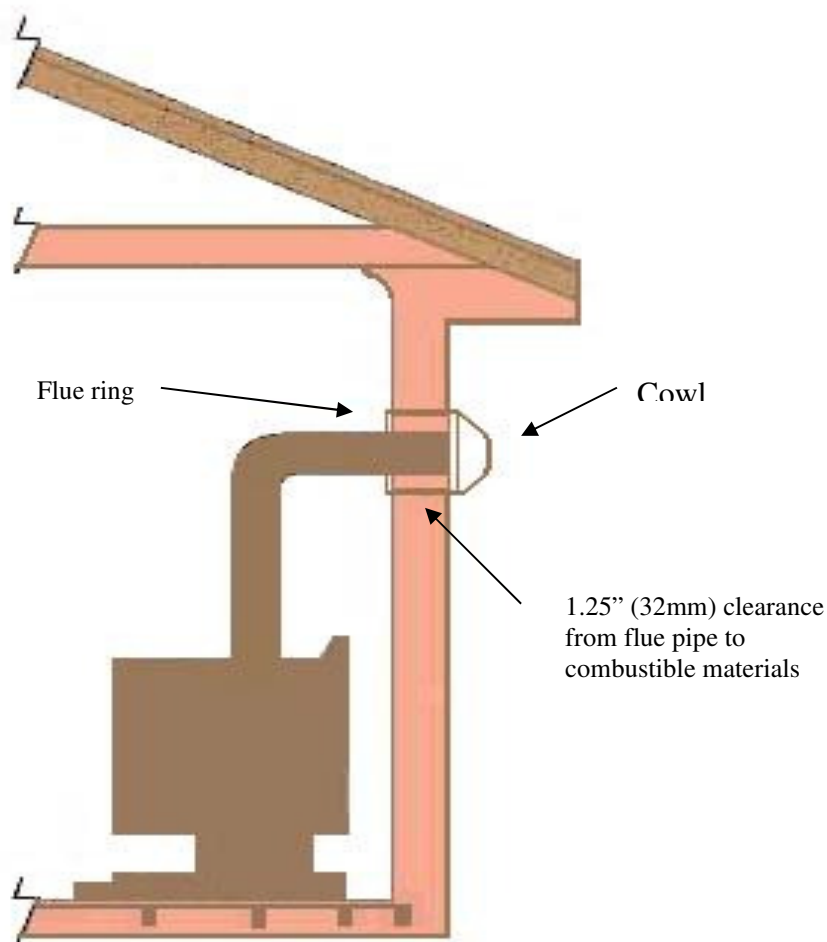

## Rear vent Flue Installation

1. Determine the exact location for the heater
2. Attach the outer 900 mm flue to the heater
3. Mark the exact location for the wall penetration
  - a. Determine that you will not be cutting through any vertical wall studs.
  - b. Check that the location of the wall mounted terminal conforms to the requirements of AS/NZS 5601 – Location of a Flue Terminal.
4. Cut a hole 205 mm in diameter through the wall.
5. Attach the internal wall plate centrally over the hole.
6. Fit the inner and outer 450mm flue lengths to spigots on the rear of the heater.
7. Trim the inner flue to 50mm longer than the outer flue.  
NOTE- it may be necessary to trim the outer flue depending on wall thickness.
8. Attach the cowl backing plate to the wall. Seal with silicon sealant.
9. Fit the wall cowl to the flues and attach to the backing plate.

**Inbuilt models must be placed on AC sheeting and flat level surface to prevent the unit from rattling.**

**Heater must be checked for scratches or dents prior to installation.**

**Recess plaster or masonry around back of on/off switch to allow fascia to sit flush on wall.**

## INSTALLATION

### Inbuilt Model

**Only to be carried out by an authorised person!**

**6mm Cement Sheeting required for floor installation.**

1. Carefully remove the carton from the heater, - remove heater from pallet.
2. Unpack Flue Kit (packaged separately).
3. Remove the 2 screws holding the fascia assembly to the heater surround. The fascia is secured to the heater surround by 2 lugs and can be removed by lifting the fascia upward approximately 5 mm and then forward.
4. Remove the 2 screws holding the fascia surround to the firebox body. This surround is located by 2 lugs, and is removed by lifting upwards approximately 5 mm then forward.
5. **Check** the label on the rear of the firebox to confirm gas type is appropriate for the gas supply available
6. Loosen the lower glass retaining bracket screws. Completely remove the top glass retaining bracket. - Remove the glass.
7. Unpack the log set from their separate carton and position them in the firebox as shown in the diagram on Page 15.
8. Install the flue – see Inbuilt Model – Flue installation Pages 10 & 11.
9. Locate the heater body into the fireplace cavity, or, pre-built wall cavity. Connect the gas supply, purge gas lines, check all connections for leaks, check pressures (refer page 16)
10. Fix the appliance firmly in position using the 4 angle brackets fixed to the heater body.
11. Connect the air inlet and exhaust flexible pipes to the outlets on the heater body.  
NOTE – The EXHAUST flue is colour coded RED at the heater body, both ends of the flexible flue pipe and at the collector box on the flue terminal assembly.
12. Re-assemble heater in reverse order of above. Connect electrical cord to correctly wired and earthed 240 Volt AC power point.
13. Operate heater, check operation on both, Hi and Low settings. Ensure fan operates after initial warm-up period. (Refer Trouble Shooting Guide page 17 should any problems occur.)

**Instruct customer of correct operating procedure.**

# VERTICAL FLUE INSTALLATION

## INBUILT MODEL

1. Connect flue terminal to both flexible flue pipes. The exhaust pipe is colour coded RED at each end, the exhaust outlet on the heater body and the exhaust port at the flue terminal.
2. Feed both flexible flue pipes down the flue cavity.
3. Fix flue terminal securely to top of flue cavity and seal to prevent water entry. Seal with Hi Temperature waterproof silicon sealant prior to cementing to chimney top, pop rivet circular flange to base of collector box. (Chimney installation only).
4. Connect flexible flue pipes to the correct outlet at the heater body Exhaust being colour RED

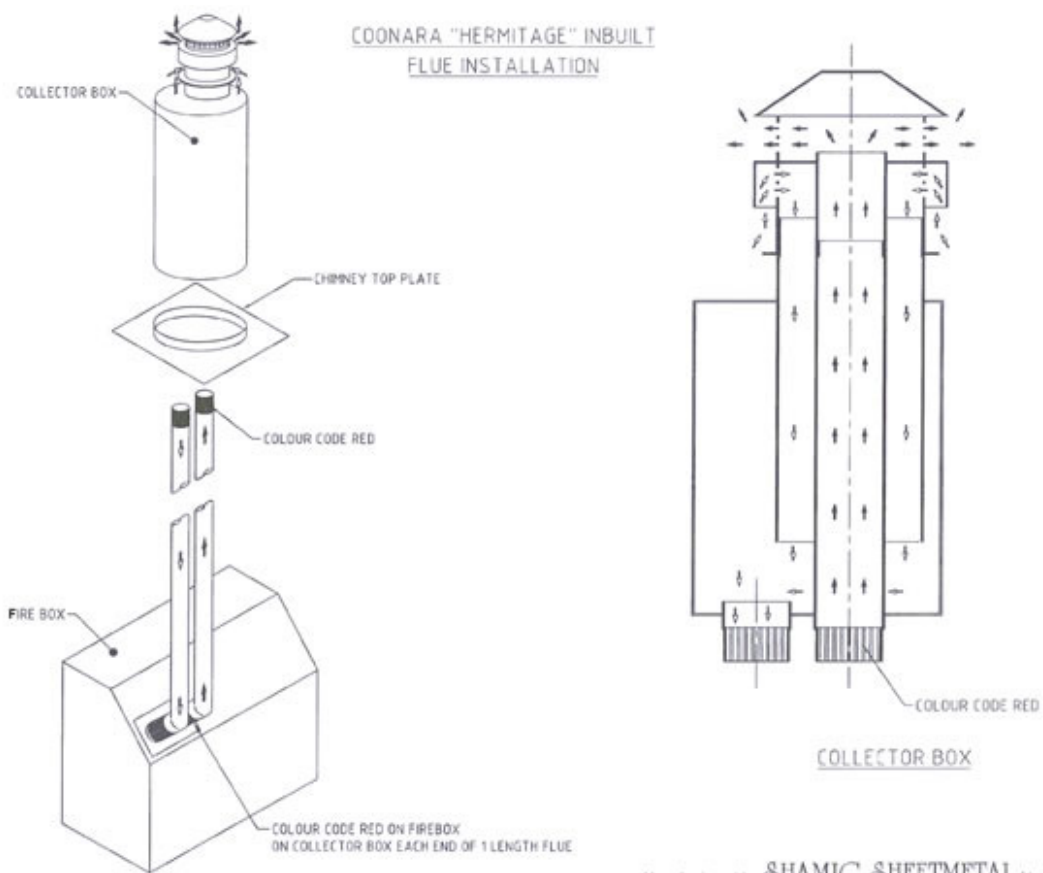

# INBUILT MODEL

## Rear vent Flue Installation

1. Determine the exact location for the heater.
  2. Mark the exact location for the wall penetration
    - a. Determine that you will not be cutting through any vertical wall studs.
    - b. Check that the location of the wall-mounted terminal conforms to the requirements of AS/NZS 5601 – Location of a Flue Terminal.
  3. Cut 2 holes 95mm in diameter at 100mm centres holes to be side by side in the horizontal.
  4. Use the back of the cowl as a template for fixing holes.
  5. Fit flex flue to spigots on the rear of the cowl using provided hose clamps and seal with silicone.
- NOTE- it may be necessary to trim the flue depending on wall thickness.
6. Attach the back of the cowl to the wall. Silicone around outside.

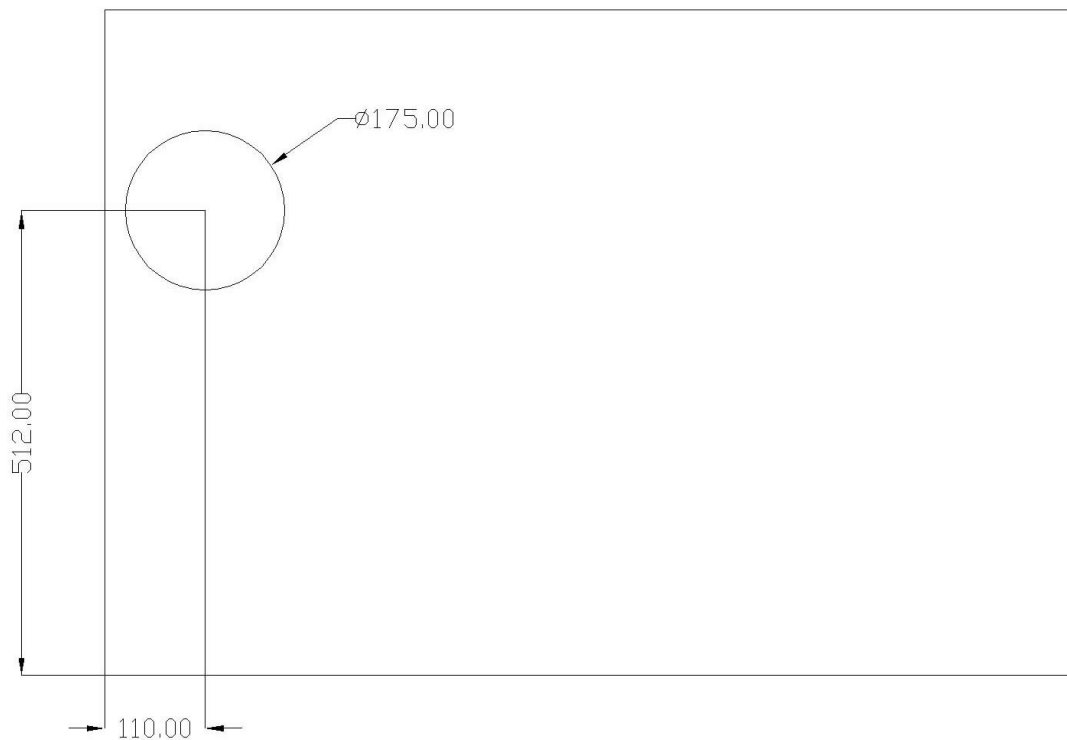

**Fig 1: Rear of heater showing exact location of flue (shown from rear).**

### **Installation in a Stud wall cavity.**

1. Mark the exact location of where the heater is to be located with an outline 720mm wide by 615mm high
2. Check that location for the flue terminal conforms to the requirements of AS/NZS 5601 Location of a Flue Terminal.
3. Cut out the plaster board and timber supports (re-position supports if necessary)
4. Refer to figure 1, and continue as described on previous page.
5. When completed, fit the “console cover” supplied to the heater fascia surround. Fit to the heater body. Attach heater fascia.

### **Installation through the wall.**

1. Mark the exact location of where the heater is to be located with an outline 720mm wide by 615mm high.
2. Check that location for the flue terminal conforms to the requirements of AS/NZS 5601 Location of a Flue Terminal.
3. Cut out the plasterboard and timber supports (re-position if necessary). Cut out the outer brickwork.
4. Feed the gas line through the hole located at the lower right hand side of the outer weather cover (provided) and the flue pipes through the pre-punched hole for the flue pipes on the upper left hand side.
5. Locate the appliance, connect gas.
6. Fit the outer weather cover over the exposed heater body and screw to the outer wall. Also use a silicon sealant.
7. Fit the cowl backing plate to the outer weather cover (Also use a silicon sealant).
8. Fit the cowl to the flue pipes and then to the cowl mounting plate.
9. Firmly fix the appliance in to position using the brackets on each side of the heater casing.
10. Replace fascia surround and Fascia.

### **External weather cover assembly/installation.**

The weather cover is supplied partially assembled with only the base panel to be attached to complete the assembly (screws provided)

There is a moveable cover plate at the lower right hand of the rear panel for fitment of the gas connection.

The horizontal cowl mounting plate (which is common for both full and partial wall penetrations) has a total of 8 pre-drilled holes. For attachment to the external weather cover, the 4 inner 4.5 mm holes are utilized (screws provided). When attached to masonry or weatherboard the 4 outer 6mm holes are utilized.

Note: when the weather cover and cowl are attached it is necessary to seal the top and side edges with silicone to prevent water entry.

## **IMPORTANT!**

### **The Hermitage Gas Log Heater**

**must always be vented to the outside!**

### Minimum clearances to combustible materials

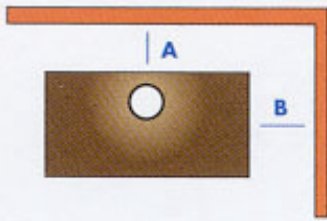

**Standard Installation**  
A. from rear wall - 25mm  
B. to nearest side wall - 150mm

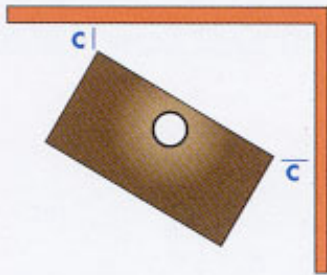

**Corner Installation**  
C. to nearest side wall - 50mm

Flue Kits - Coonara heaters are designed and tested for use with Coonara manufactured flue kits.

### Flue Installation

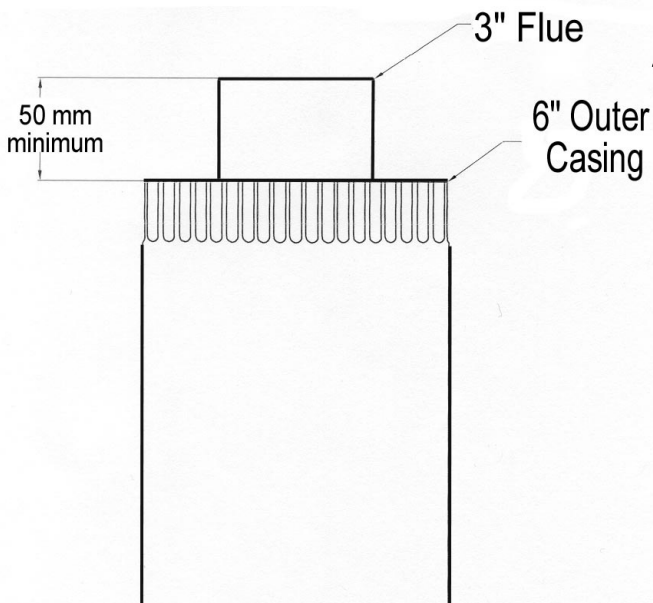
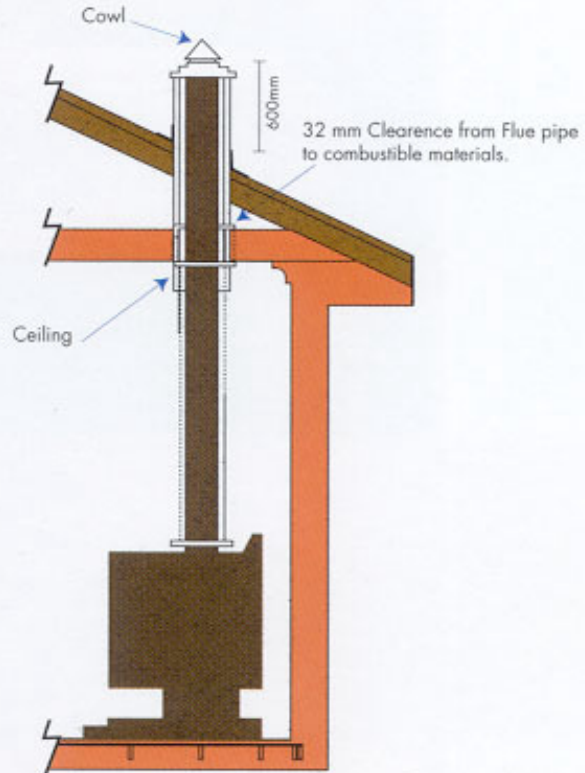

### IMPORTANT!

**Cut outer flue casing to ensure inner Flue (exhaust pipe) protrudes 50 mm above outer casing!**

**Crimped ends must point upwards!**

# INSTALLATION OF LOG SET

1. Place the rear log on the top rear burner plate as shown.
2. Place front log on the front section of the burner.
3. Fit the cross logs (as illustrated below) to the pins located on the front and rear logs. Logs should not touch the sensor or sparker.

**Ensure front log is fully forward and touching the metal stoppers. Logs should not be on top of or touching the flame sensor.**



Above diagram shows correct orientation of logs

# WIRING DIAGRAM

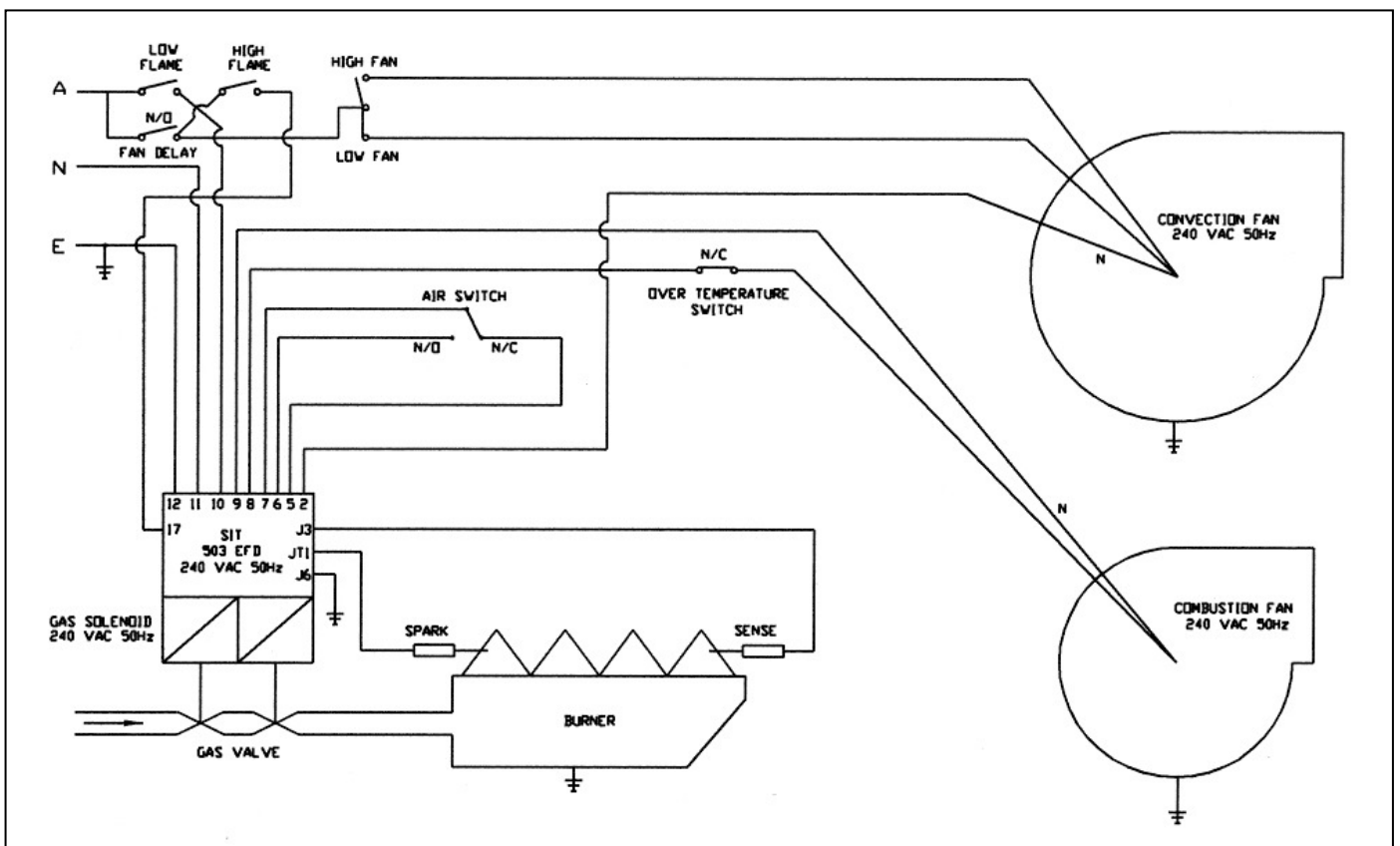

# HERMITAGE GAS VALVE

SIT 843

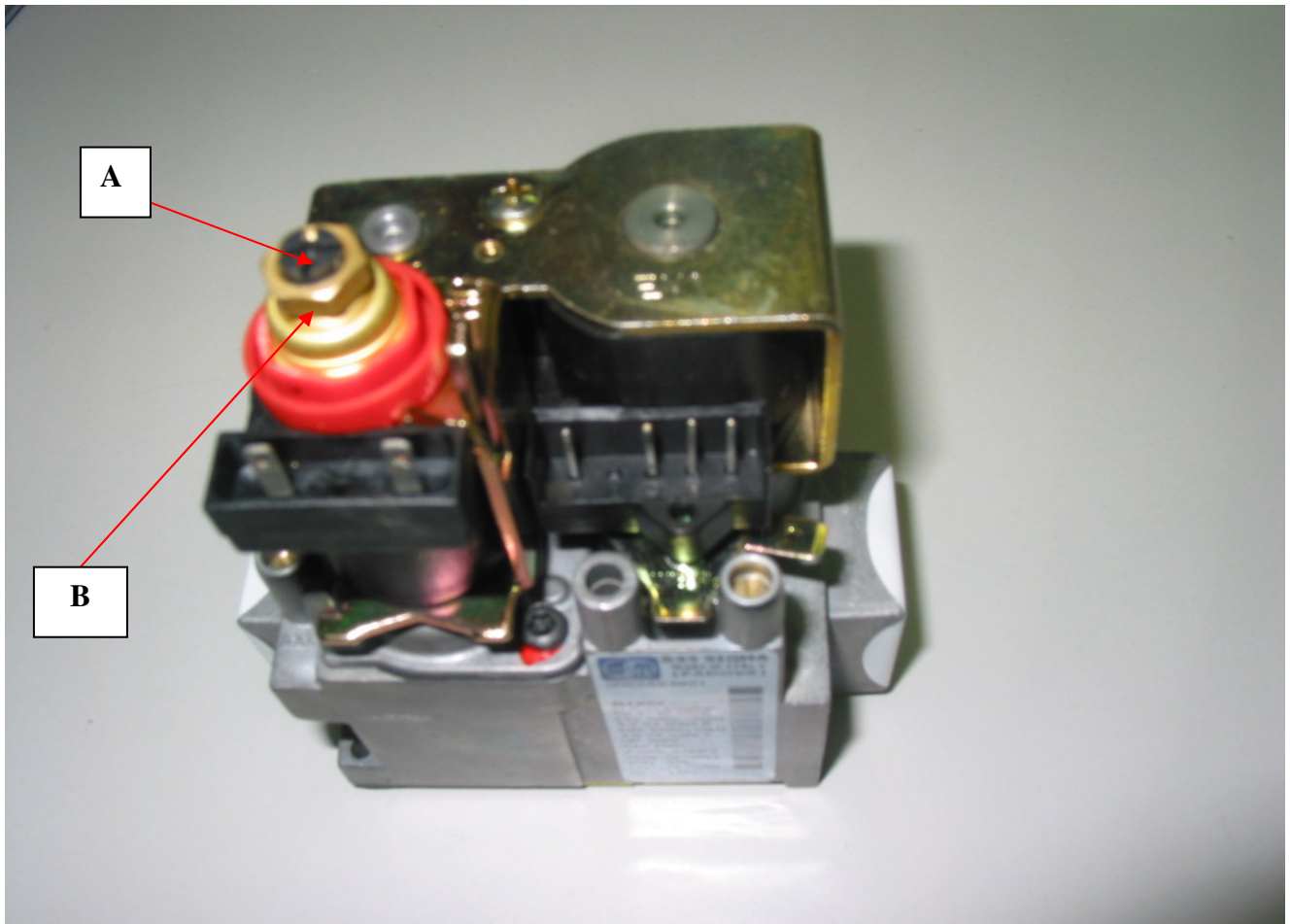

“A” represents the low gas adjustment. Turn the screw clockwise to increase gas pressure.

“B” represents the high gas adjustment. Turn the nut clockwise to increase gas pressure.

## *Natural Gas*

Burner test point pressure –	HIGH <b>0.9 kPa</b> , LOW <b>0.48 kPa</b>
Primary air shutter adjustment –	<b>fully open (Freestander)</b> <b>fully open (Inbuilt)</b>
Natural gas injector orifice –	<b>2.8mm diameter</b>

## *LPG Gas*

Burner test point pressure -	HIGH <b>2.50 kPa</b> , LOW <b>1.30 kPa</b>
Primary air shutter adjustment –	<b>fully open (Freestander)</b> <b>fully open (Inbuilt)</b>
Propane gas injector orifice –	<b>1.7 mm diameter</b>



# TROUBLESHOOTING GUIDE

PROBLEM	POSSIBLE CAUSE	REMEDY
Appliance fails to ignite.	No gas or supply pressure insufficient.	Ensure gas supply connected, purged, and pressure appropriate.
	No electrical supply.	Ensure unit plugged in and switch is on, check supply fuse.
	Incorrectly wired power point.	Check supply. Active, neutral, & earth must be correctly orientated and connected.
	Incorrect gas valve adjustment.	Adjust valve pressures.
	Insufficient time allowed between attempts.	Wait at least 15 seconds for unit to purge combustion chamber after switching on.
	Internal wiring disconnected.	Check all plugs inside appliance are connected properly and correctly located, Ensure operation of combustion fan & air pressure switch.
Unit will not operate on Low.	Incorrect gas valve adjustment.	Adjust valve.
	Incorrect or loose wiring.	Check wiring.
Room fan not operating.	Insufficient time allowed.	Fan has a delayed start and will not start until unit warms-up.
	Loose wiring.	Check wiring.
	Fan not located correctly.	Install fan in correct location.
	Fan blocked.	Remove and clean fan.
Unit cuts out after a period of time then cycles on and off.	See "Room fan not operating"	See "Room fan not operating"
	Heat exchanger blockage.	Clean heat exchanger.
	Excessive pressure or incorrect gas type.	Ensure correct gas type, injector size, and pressure setting.
Excessive carbon (soot) deposits on inside of firebox, logs, and/or glass.	Incorrect gas type or pressure setting.	Ensure correct gas type, injector size, and pressure setting.
	Primary air shutter incorrectly adjusted for gas type.	Adjust primary air shutter.
Excessive flame height.	Incorrect gas type or pressure setting.	Ensure correct gas type, injector size, and pressure setting.
Excessive flame "lift off"	Flue or inlet blockage.	Clear blockage.
	Recirculation of flue gases.	Flue incorrectly installed.
Unit fails to heat.	See "Room fan not operating"	See "Room fan not operating"
	Incorrect gas type or pressure setting.	Ensure correct gas type, injector size, and pressure setting.
	Gas supply blockage.	Check injector, burner supply pipe, & valve for foreign matter.

**All service work to be carried out by a qualified & authorised person.**

## DIMENSIONS

<b>Freestanding</b>	<b>Inbuilt</b>
Overall height - 750 mm	Overall height - 720 mm
Overall Width - 600 mm	Overall width - 875 mm
Overall Depth - 480 mm	Overall depth - 605 mm
Weight - 74 kg	Weight - 84 kg
Clearance to combustibles: From either side of appliance - 150 mm *From rear of appliance - 0 mm In front of appliance - 1500 mm	Firebox Casing Dimensions: Height - 595 mm Width - 695 mm Depth (from rear of fascia) 425 mm
<i>*Allow at least 25mm for power lead exiting rear of appliance.</i>	Clearance to combustibles: From firebox casing From either side of appliance - 12mm From top horizontal surface 20 mm From flue connector box 35mm In front of appliance 1500mm
Location of gas connection: (flexible connection) Rear of appliance 75mm above base 140mm from right side of unit	Location of gas connection: (flexible connection) Rear of appliance 50mm above base 250mm from right side of unit
POWER FLUE – ZERO CLEARANCE	POWER FLUE – ZERO CLEARANCE

## How to Make a Warranty Claim

### Coonara, Heatcharm, Arrow and Settler Heaters.

The full Warranty Statement for your heater is contained in the Installation and Operating Instructions booklet that was provided with the product.

1. Check the details of the warranty statement
2. Determine if you think the problem is covered by warranty
3. Ensure that you have proof of purchase
4. Contact the retailer that sold you the heater
5. Advise them of the specific problem
6. Provide the details that your retailer requests to complete a Warranty Claim Form. This must include the heater model, serial number and installation compliance certificate, if applicable in your State.
7. Your retailer will forward your claim to Shamic Sheetmetal (Aust) Pty Ltd, the manufacturer of the above heater brands
8. Shamic will contact you to acknowledge that they have received the claim, if the claim has been accepted and the next steps involved in fixing the problem
9. Parts and/or service is provided
10. Contact your retailer if the problem has not been fixed.

# WARRANTY

DESIGNATION OF WARRANTOR. This warranty is extended by Shamic Sheetmetal (Aust) Pty. Ltd with respect to Coonara gas heaters

PRODUCT. This Coonara gas heater is comprised of the heater proper (including components and firebox), fan assembly, speed control switch, electrical components, gas valves, seals and moving parts. Except where specifically excluded from coverage hereunder, this warranty covers all components designed.

See exclusions and qualifications below for further information on product coverage.

## WARRANTY:

- 1) Shamic Sheetmetal (Aust) Pty. Ltd warrants the firebox and the heat exchanger to be free of defects in materials and workmanship of a period of five (5) years from the date of purchase.
- 2) Shamic Sheetmetal (Aust.) Pty.Ltd. warrants that all other components of the unit to be free of defects in material and workmanship for a period of two (2) years from date of purchase, excluding door glass.
- 3) If this Coonara heater is found to be defective in material or workmanship Shamic will repair or replace such defects in the Coonara heater at Shamic's option in accordance with Coonara's warranty policy during the period on this warranty. If the defect is found not to meet the Consumer Guarantee requirements and constitutes a major failure, the purchaser may be able to choose to repair or replace the defective heater or part or obtain a refund.
- 4) Exclusions and qualifications. This warranty is subject to the following exclusions and qualifications.
  - a) This warranty extends only to the original consumer purchaser, who has purchased the heater from an authorised Coonara dealer.
  - b) This warranty does not apply to, and Coonara assumes no responsibility for any damages that result due to, installation or operation of the heater not in accordance with both the installation and operation instructions furnished with the unit.
  - c) This warranty does not apply to any heater which has been modified or damaged in shipping or by improper handling, improper operation, abuse, misuse, accident or unworkmanlike repairs.
  - d) Shamic Sheetmetal (Aust.) Pty.Ltd. does not warrant the structural performance of the heater when fuel products other than the specified gas fuels are used. Flammable liquid fuels are explosive and should never be used in this product.
  - e) Shamic Sheetmetal (Aust.) Pty.Ltd. expressly excludes any liability hereunder for defects or damage caused by the installation or of any components not expressly authorised and approved by Shamic. Shamic further assumes no liability for defects or damage caused by any modification not expressly authorised and approved by Shamic. Unauthorised components or modifications could create a fire hazard by altering the safety design of the heater.
  - f) Building Codes. Since building code requirements vary, users should determine in advance whether there are any building code restrictions on the installation or use of the heater. Shamic makes no representation of warranty regarding building code compliance and shall not be responsible for compliance therewith.
  - g) Shamic will only accept claims under this warranty in strict accordance with the conditions set out below.
- 5) Shamic Sheetmetal (Aust.) Pty.Ltd. shall not be liable for any breakages of glass and log components, transit damage or, where it can be shown that the consumer guarantee obligations as the manufacturer have been met, for any claim by any person for incidental or consequential damages caused by defects in the Coonara heater. Whether such damage occurs or is discovered before or after replacement or repair, and whether or not such damage is caused by Coonara negligence. Normal wear and tear items such as routine surface maintenance, seals and door glass are also excluded from this warranty.
- 6) Shamic goods come with guarantees that cannot be excluded under Australian Consumer Law. The purchaser is entitled to a replacement or a refund for a major failure and compensation for any reasonably foreseeable loss or damage. The purchaser is also entitled to have the goods repaired or replaced if the goods fail to be of acceptable quality and the failure does not amount to a major failure.
- 7) This warranty applies only to units purchased from an authorised dealer and the duration of this implied warranty, including merchantability, applicable to this Coonara heater is limited to the duration of the foregoing warranty.
- 8) Before Shamic Sheetmetal (Aust.) Pty.Ltd. will recognise or accept a claim under this warranty, you must provide proof of purchase. On purchase of the heater, despatch your warranty card to Shamic Sheetmetal (Aust.) Pty.Ltd.
- 9) Your authorised dealer must be notified of any defect in the heater, for investigation of the claim. In the event where a remedy is necessary and the claims under warranty are accepted, the purchaser may be required to return the goods to the authorised dealer for repair, replacement or refund.

## CARE OF YOUR Hermitage GAS HEATER

This appliance requires minimal maintenance, however, it is recommended that a full service and check be made by a qualified person annually.

The fascia should be removed, and the fan vacuumed annually.

To clean the appliance, simply wipe over with a damp cloth. **Do not use solvents or abrasive cleaning agents.**

Before calling for service, check that:

- ! Electrical power is switched on.
- ! Gas is turned on.
- ! There are no obstructions/blockages of the flue terminal.

This appliance incorporates a live fuel effect and is designed to operate with luminous flames. The appliance may exhibit slight carbon deposit (sooting). Refer to the Troubleshooting Guide on page 17 for instructions relating to cases of excessive carbon deposit.



**The Warmest Aussie Legend**

For your nearest authorised service company, please contact:

**SHAMIC SHEETMETAL (AUST.) PTY. LTD.**

14 – 18 Research Drive, CROYDON SOUTH, VIC. 3136

**POSTAL ADDRESS:**

P.O. Box 8, KILSYTH, VIC. 3137

Phone: (03) 9737 5300

Email: info@shamic.com.au



**DETACH AND RETURN BY MAIL**



NAME \_\_\_\_\_

ADDRESS \_\_\_\_\_

CITY / STATE / POSTCODE \_\_\_\_\_

PURCHASED AT (Dealer name & address) \_\_\_\_\_

DATE PURCHASED \_\_\_\_\_ MODEL \_\_\_\_\_ SERIAL NO \_\_\_\_\_

WHERE DID YOU HEAR ABOUT HERMITAGE GAS HEATERS?

RADIO, TELEVISION, NEWSPAPER, DEALER, WEBSITE, OTHER – please provide details.